



MADE IN GERMANY

SEBO AIRBELT E

OWNER'S MANUAL

For Household Use Only

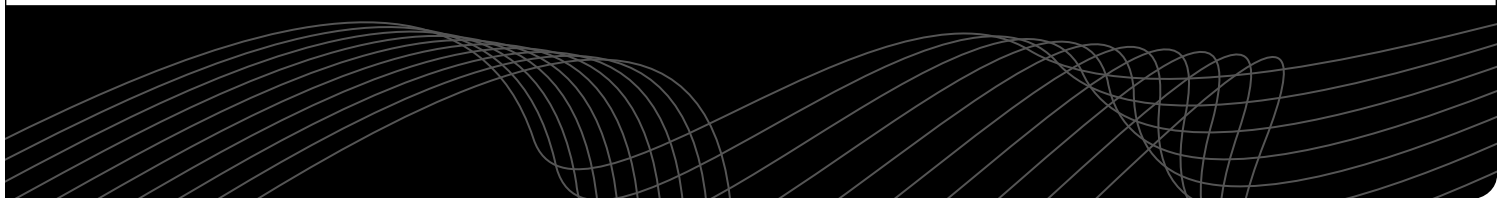

TABLE OF CONTENTS

Technical Details	2
How To Contact SEBO	2
Important Safety Instructions	3
AIRBELT E Product Features	4
AIRBELT E1 Kombi & E2 Turbo Features	5
AIRBELT E3 Premium Features	5
Optional Attachments, Accessories, Bags and Filters	6
Standard Features of All SEBO Vacuums	7
Identification of Parts	8
Standard Attachments	8
Brushes and Heads	8
Assembly	8
Operating Instructions	9
Starting the Machine	9
Suction Control	9
Brush Roller Switch - E3 Premium	10
Adjusting the Telescopic Tube	10
Using the Telescopic Tube, Hose & Attachments	10
Bag Full or Clog Indicator & Automatic Shut-off	10
Retracting the Cord	11
Storing the Vacuum	11
Use and Maintenance of Brushes and Heads	11
Parquet Brush	11
Premium Parquet Brush	11
TT-C Turbo Head	11
Kombi Nozzle	11
Premium Kombi Nozzle	11
Vacuum Maintenance	12
Changing the Filter Bag	12
Changing the Pre-motor Filter	12
Changing the Exhaust Microfilter	12
Changing the AIRBELT Textile	13
Clog Removal	14
Clogs in the Head or Brush	14
Clogs in the Telescopic Tube	14
Clogs in the Hose	14
Clogs in Entrance to Filter Bag	14
Trouble-shooting Guide	15
AIRBELT E1 Kombi & E2 Turbo Schematic and Part Numbers	16
AIRBELT E3 Premium Schematic and Part Numbers	17

TECHNICAL DETAILS

Vacuum motor	1200 watts	Motor protection	Thermal cut-out
Filter bag capacity	.92 gallons	Cord length	25 feet
Body weight	11.4 lbs	Range	37 feet

Technical details may be subject to change.

HOW TO CONTACT SEBO

To contact SEBO in the United States of America:
SEBO America, LLC
Telephone: (800) 334-6614
Fax: (303) 792-9196
Website: www.sebo.us

To contact SEBO in Canada:
SEBO Canada
Telephone: (877) 258-5005
Fax: (800) 270-4807
Website: www.sebocanada.ca

For Warranty coverage information please refer to your Warranty Card included with your SEBO vacuum cleaner.

IMPORTANT SAFETY INSTRUCTIONS



READ ALL INSTRUCTIONS BEFORE USING THIS MACHINE

When using an electrical appliance, basic precautions must always be followed.

To reduce the risk of electric shock, this vacuum cleaner has a polarized plug; one blade is wider than the other. This plug will fit in a polarized outlet only one way. If the plug does not fit fully in the outlet, reverse the plug. If it still does not fit, contact a qualified electrician to install the proper outlet. Do not change the plug in any way. Connect only to the outlet type specified on the serial number plate underneath the machine.

SAVE THESE INSTRUCTIONS.

WARNING: To reduce the risk of fire, electric shock, or injury:

1. Do not leave vacuum while plugged in. Unplug from outlet when not in use and before servicing.
2. Do not use outdoors or on wet surfaces.
3. Do not use near small children or pets. Do not allow to be used as a toy. Use of this product by children should always be supervised by an adult.
4. Use only as described in this manual. Use only manufacturer-recommended attachments.
5. Do not use with a damaged cord or plug. If vacuum is not working as it should, has been dropped, damaged, left outdoors, or dropped into water, take it to a SEBO service center.
6. Do not pull or carry by cord, use cord as a handle, close a door on cord, or pull cord around sharp edges or corners. Do not run vacuum over cord. Keep cord away from heated surfaces.
7. Do not unplug by pulling on cord. To unplug, grasp the plug – not the cord.
8. Do not use outlets above counters to plug in vacuum – damage to items in the surrounding area could occur.
9. Always carry the vacuum over steps and sills.
10. Do not handle plug or vacuum handle with wet hands.
11. Do not put any object into vacuum openings. Do not use machine with any openings blocked. Keep openings free of lint, hair, and anything that may reduce air flow.
12. Do not re-use filter bags or wash the filters.
13. Do not remove any screws from vacuum.
14. Do not vacuum up anything that is burning or smoking, such as cigarettes, matches, or hot ashes.
15. Do not use vacuum without filter bag and/or filters in place.
16. Turn off all machine controls before unplugging.
17. Use extra care when cleaning on stairs.
18. Do not use machine to vacuum up flammable or combustible liquids such as gasoline or use in areas where they may be present.
19. Machines can cause a fire when operated near flammable vapors or materials. Do not operate this vacuum near flammable fluids, dust or vapors.
20. Maintenance and repairs must be done by authorized personnel.
21. Use only original SEBO replacement parts.
22. Do not use vacuum as a step.
23. If vacuum is used on plush carpet or carpet with thick padding, do not leave machine standing in one place with machine turned on.
24. While the vacuum is in use, the power cord should be unwound from the cable reel at least two thirds of its length. Hold plug when rewinding onto the cord reel. Do not allow plug to whip while rewinding.
25. Keep hair, loose clothing, fingers, and all parts of body away from vacuum openings and moving parts. Do not place fingers or other body parts under vacuum unless it is unplugged.
26. Do not place the power head over rug or carpet edges.
27. The vacuum has a manual reset thermal protector. The protector is reset by switching off the vacuum. The thermal protector needs some time to cool down after switching off! Check the vacuum for air blockages or mechanical failures before switching on.
28. Store the vacuum in a dry place at room temperature. When the vacuum is not in use, you should rewind the cord onto the cord reel
29. The E3 hose contains electrical wires. Do not use if damaged, cut, or punctured. Avoid picking up sharp objects.
30. Always unplug vacuum before connecting or disconnecting either hose or power head.
31. Use a SEBO power head only in combination with a SEBO vacuum cleaner.
32. Do not connect power head to a malfunctioning or damaged vacuum.

SEBO AIRBELT E PRODUCT FEATURES

Bag Full or Clog Indicator & Auto Shut Off –

The warning indicator will show orange when it senses a full bag, a clog in the airflow pathway, or an excessively dirty micro filter. If the user ignores this warning, the suction motor will shut off to protect itself from damage, usually within 6-10 minutes.

The user should turn the switch off, unplug the machine and immediately insert a new bag or remove the clog (to remove a clog, refer to the Clog Removal section on page 13) and restart the machine. If the airflow is still restricted, the indicator will again show orange and the above sequence will be repeated.



Shock Absorber Provides Furniture and Wall Protection –

The patented "AIRBELT" bumper that surrounds the E canisters acts as a protective barrier. The soft foam bumper with its durable textile cover protects furniture, walls and the vacuum itself from damage during use. The bumper also diffuses exhaust air, which contributes to its ultra-quiet performance.



Quick-release Connections – The AIRBELT E models allow for quick and convenient connection of telescopic tubes, power brush heads, accessory cleaning heads and on-board tools.

Comfortable Ergonomic Handle – The AIRBELT handles are ergonomically designed and positioned to reduce wrist and arm fatigue. For extra comfort, an additional swivel is built into the handle-to-hose connection.

Mid-sized Canister Vacuum – The AIRBELT E models are considered mid-size canister vacuums, which means they are smaller, more compact machines that offer three full-size on-board tools and a large filter bag with a capacity of .92 gallons. The large capacity filter bag is economical because fewer bag changes are needed. An indicator window turns orange when the filter bag needs to be replaced, and closing its built-in hygiene cap prevents dust from escaping during bag removal and disposal.



Three Protective, Rubber-coated Wheels, mounted on steel axles – The superb rubber-coated castor-wheels glide easily and gently over all floor types, providing exceptional maneuverability and protection of floor surfaces.



Flat-to-the-floor 3-1/2" Profile – A low cleaning-head profile makes reaching under furniture and beds easy!

Long, 25-foot cord and 37-foot Operating Range – The large cleaning radius saves time because it can clean large areas without changing electrical outlets. Plus, the 7-foot suction hose provides superb user maneuverability.

Push-button Cord Rewinder – The super-long power cord rewinds by simply pressing a button.

Large-capacity Filter Bags – The .92-gallon filter bag is convenient and economical because fewer bag changes are needed, and closing its built-in hygiene cap prevents dust from escaping during bag removal and disposal.

Convenient Parking and Storage Aids – After the work is done, the suction hose with telescopic tube and Parquet Brush, Turbo Brush or Kombi Nozzle can be firmly stored on the canister's underside or backside housing.

Three Full-size On-board Tools – The vacuum comes standard with a crevice nozzle, dusting brush and upholstery nozzle. The dusting brush is mounted on the telescopic tube, and the crevice and upholstery nozzles are on the canister. Many optional accessories are also available.

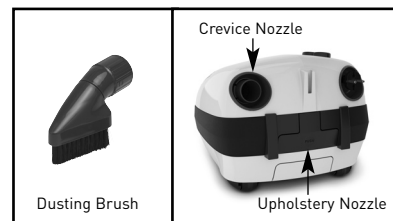

AIRBELT E1 Kombi and E2 Turbo

The SEBO AIRBELT E1 Kombi and E2 Turbo are straight-suction vacuums. As a result, they differ from the AIRBELT E3 Premium in the following two ways:

Suction-control Knob on Canister Body – Because the E1 and E2 models have hoses and telescopic tubes without power cords, their suction-control knobs are located on their canister bodies, not the handles.



Can Not Use a Power Brush – The AIRBELT E1 Kombi and the AIRBELT E2 Turbo do not have an electrified telescopic tube and hose; therefore, they do not accommodate an electrified power brush. Instead, the AIRBELT E1 Kombi comes standard with the Kombi Nozzle, and the AIRBELT E2 Turbo comes standard with the TT-C Turbo Head for carpet and a Parquet Brush for hard floors. Both models clean hard floors and rugs.



TT-C Turbo Head

Parquet Brush

Kombi Nozzle

AIRBELT E3 PREMIUM

Designed for All Floor Surfaces.

AIRBELT E3 Premium:

The AIRBELT E3 has an electrified hose and telescopic tube designed to accommodate the ET-1 power head. The ET-1 power head is designed to provide thorough brushing for optimal cleaning of carpets.

Both Carpet and Hard Floor Cleaning –

With a power brush to clean carpets and a parquet brush to clean hard floors, the AIRBELT E3 provides all the flexibility needed to care for a variety of floor surfaces. The parquet brush comes standard.

High-quality Telescopic Tube and Hose –

On the E3, the power cord is built inside the telescopic tube and suction hose. This eliminates unsightly external wires and enables unobstructed and convenient handle height adjustment.

Suction-adjustment Slider – The vacuum's suction power can be adjusted from 0 to 1,200 watts by a slider switch conveniently located on the handle.

Brush Roller Switch on Handle – To switch from brushing action to straight suction for delicate floors, press the brush roller power switch on the handle. This will power off the brush roller on the power head. All indicator lights on the power head will turn off until the brush roller button is switched on again.



Parquet Brush

Powerful Vacuum Motors Provide Excellent Cleaning –

The canister suction motor is 1,200 watts, and the power head motor is 175 watts (ET-1), for a total of 1,375 watts.



The SEBO ET-1 (12" wide, 10 1/2" cleaning width) – This power head delivers cleaning flexibility because its brush action aggressively cleans carpeting, but the brush roller may be switched off on the handle, so delicate rugs and hard floors can be cleaned with straight suction. Its amazing 180° steering ability provides maneuverability around furniture, and the extension side of the L-shaped head makes cleaning edges and under counters easy.

Brush Obstruction Light & Auto Shut Off –

If an obstruction becomes jammed in the brush roller, a red brush-warning light will quickly flash, the brush roller will immediately stop spinning and the vacuum will shut off. The user should turn the power switch off, unplug the machine, and immediately remove the obstruction. If the user restarts the machine without removing the obstruction, the power head will again shut off and the red light will flash. This prevents the belt from breaking and protects the motor and carpet from damage.



Incorrect Height Setting or Brush Deterioration Light – To ensure optimum cleaning at all times, a red brush-warning light will illuminate, to indicate when the brush height is set too high for effective cleaning or when the brush roller should be replaced due to excessive wear.

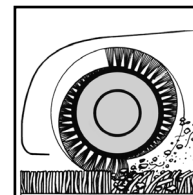

OPTIONAL ATTACHMENTS, ACCESSORIES, BAGS & FILTERS

In addition to the standard on-board tools, a variety of optional attachments are available. The 9' 2" extension hose (extends suction hoses) and the 22" extension wand are very popular because they create useful tools for cleaning stairs and out-of-reach areas. Another popular attachment is the Hand-held Turbo Brush for removing pet hair from upholstery.

SEBO AeraPure™ filter bags can be purchased in boxes of eight and filters are sold separately. SEBO bags, filters and accessories are reasonably priced and widely available. To create a fresh scent while vacuuming, SEBO FRESH is available. To use, deposit a scented stick in the filter bag.

ATTACHMENTS

Included all E Models



Dusting Brush
Horsehair Bristles
#1387GS



Upholstery Nozzle
#8210GS



Crevice Nozzle
#8066GS

Included E3 Premium Models



ET-1 Power Head
Black, Red,
White, Graphite



Parquet
Brush
#6391DA

Included E2 Turbo Models



TT-C Turbo Head
#8365GS



Parquet
Brush
#6391DA

Included E1 Kombi Models



Kombi Nozzle
#8351GS

Optional Attachments



24" Crevice Nozzle
#1093JV



22" Extension Wand
#1084GS



9' 2"
Extension Hose
#1495AM



Hand-held
Turbo Brush
#6179ER



Flat Upholstery
Nozzle
#1090HG



Wall & Floor
Brush
#1325GS



Turn and Clean
Parquet Brush
#1327WS



Dusting Brush
Nylon Bristles
#1329GS



Dusting Brush
Large Opening
Nylon Bristle
#1094GS



Premium
Parquet
Brush
#7200GS



TT-C Turbo Head
#8365GS



Premium
Kombi Nozzle
#7260GS



Kombi Nozzle
#6735GS



Kombi Nozzle
#8351GS



Radiator
Brush
#1496GS

BAGS, FILTERS, ACCESSORIES AND WEAR ITEMS



8 AeraPure™
Bags
#8300AM

Filter Set includes a
Pre-motor Filter and an
Exhaust S-class Microfilter.
#8322AM



Service Box includes 8 bags,
a Pre-motor Filter
and an Exhaust
S-class Microfilter.
#8334AM



12" Brush Roller
#5010AM



12" Brush Roller
(Soft Bristle)
#5010GE



AIRBELT Cover
Gray/Black, Solid
#8221AM01

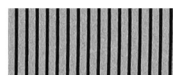

AIRBELT Cover
Black/Silver, Stripes
#8221AM10

SEBO FRESH
1 Pkg. of 5
#0496AM



NOTE: The optional **Premium Parquet Brush** and **Premium Kombi Nozzle** have brush strips that are removable for cleaning and replacement. To change the brush strip, remove the yellow cap with a screw driver and pull out the brush strip. After inserting the new brush strip, the cap has to click into place again.

STANDARD FEATURES OF ALL SEBO VACUUMS

SEBO's FILTRATION SYSTEM:

Bagged vs. Bagless . . . Bags are Better! –

Top-fill, three-layer AeraPure™ Bags are an integral part of SEBO's filtration system because they hold virtually all the dirt captured by the vacuum, which improves the effectiveness and useful life of the microfilters. They also ensure continuously strong suction because dirt enters from the top, deposits at the bottom, accumulates upward, and air exits through the sides, which allows unimpeded airflow as they fill to capacity. And they can be tightly sealed with a hygiene cap when full, so no dust can escape into the air during bag removal and disposal.

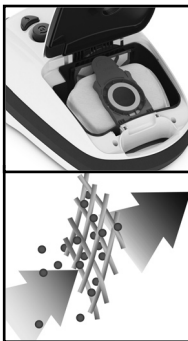

In contrast, without bags to hold nearly all the captured dirt, the microfilters on bagless vacuums quickly clog from excessive dirt build-up and must be replaced often, or a loss of suction and cleaning effectiveness will occur. In addition, dust and other allergens become airborne when emptying bagless dirt containers. Lastly, bagless vacuum microfilters are expensive, usually costing more than a multi-year supply of SEBO filter bags.

S-class, Pre-motor and/or Exhaust Microfilters –

S-class, Pre-motor and Exhaust Microfilters (S = "Schwebstoff" = airborne particles) are made from electrostatically charged, micro-fiber material, which attracts and captures dust particles from the airflow of the vacuum before and after it passes over the motor to cool it. Cooling the motor with super-clean air increases motor life and reduces the possibility of maintenance, even after many years of use. Also, the exhaust air is cleaned to the highest level before being emitted from the machine. The S-class Standard requires filters to absorb greater than 99.9% of particles down to 0.3 microns in diameter. For comparison, 100 microns is the diameter of a human hair. Their advantages are a relatively open texture that allows smoother airflow for better suction performance, a longer life expectancy, and they cost less than HEPA filters.



HEPA, Pre-motor and/or Exhaust Microfilters (Optional) –

HEPA Microfilters ("High Efficiency Particulate Air") remove a minimum of 99.97% of all airborne particulate matter down to 0.3 microns in diameter. Because these filters use small, grid-like structures to capture dust particles, dirt build-up clogs the airflow pathway sooner than what is expected from S-class microfilters. However, SEBO's HEPA microfilters are sold along with three-layer AeraPure™ bags, which provide highly effective filtration before the airflow goes through the HEPA microfilter, greatly increasing life expectancy and reducing the potential of diminished air flow.

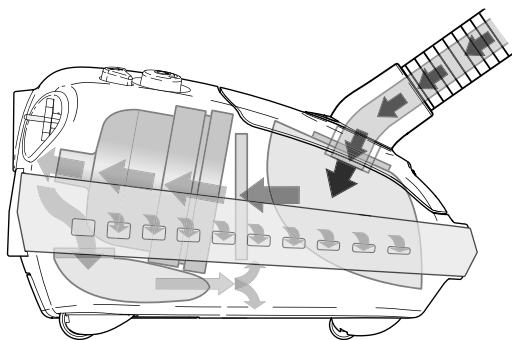

Designed and Manufactured in Germany – Legendary quality, reliability and performance make SEBO vacuums the first choice of cleaning professionals throughout the world.

World's Best Pet Vacuums – Because of superior power-head and brush-roller technology, SEBO vacuums are the world's best for pet hair removal!

Tightly Sealed Vacuums Ensure Effective Filtration – Dirty air, which flows through a vacuum, can only be filtered completely if it does not escape into the room through seams or seals in the machine. This is why all SEBO vacuums have tight seals throughout.

Many vacuum companies with high-filtration claims are actually quoting specifications made by the manufacturer of the filter material, as measured in the laboratory, not the filtration effectiveness of the vacuum itself while operating. Whether or not dirty air can escape through leaks in the body of the machine is not considered. The filtration effectiveness of SEBO vacuums is tested while they operate.

Reliable, Commercial-grade Components – All SEBO vacuums are constructed with thick, reinforced, ABS plastic, aluminum and metal parts, steel axles and bearings, and high-end, quality motors. Therefore, SEBO users own reliable, long-lasting vacuum cleaners. Competing vacuums are made with thin, flimsy, inexpensive, plastic materials, none of which are reinforced, and typically have useful lifespans of one or two years.

Rubber Wheels and Soft Bumpers Protect Homes – Smooth-gliding, rubber wheels protect hard floors and provide exceptional maneuverability. In addition, the bumpers that surround the power heads and the soft AIRBELT bumpers that surround SEBO's canisters protect furniture, walls, and vacuum housings from incurring scuffs and scratches during use.

Advanced, Brush-roller Technology – SEBO's brush rollers are uniquely designed to funnel hair and debris into the power head's airflow channel, which improves vacuum cleaning performance on all flooring surfaces.

Changing Bags is Easy and Clean – SEBO filter bags can be changed in just a few seconds, and a hygiene cap keeps dust sealed inside during removal and disposal.

Save Money! SEBO Vacuums Last for Years and Extend Carpet Life!

– If properly maintained, SEBO vacuums save ordinary, residential users hundreds of dollars, by providing excellent performance for ten to fifteen years or more, and their deep-cleaning, power-brush technology extends the life of carpets. Typical vacuums perform poorly, even when new, and usually do not last beyond two years. So six or seven "disposable vacuums" must be purchased during the average life expectancy of just one SEBO machine.

Incredible Warranty Coverage – All SEBO models include a FREE seven-year warranty on the motor and five-years on non-wear parts and labor charges.

IDENTIFICATION OF PARTS

- | | |
|---|--|
| 1. Handle grip | 13. Carrying handle |
| 2a. Suction-control slider (E3 Premium) | 14. Hose neck release buttons |
| 2b. Brush roller switch (E3 Premium) | 15. Warning indicator |
| 3. Handle release button | 16. Suction opening |
| 4. Slide button | 17. Filter bag cover release catch |
| 5. Telescopic tube | 18. Parking attachment groove |
| 6. Tool release button | 19. Exhaust filter cover |
| 7. Kombi nozzle | 20. Exhaust filter cover release buttons |
| 8. Hose | 21. Power cord |
| 9. Push-button cord rewriter | 22. Parking attachment groove |
| 10. On/off power knob (E3 Premium) | 23. Crevice nozzle |
| On/off power and suction-control knob (E1 & E2) | 24. Upholstery nozzle |
| 11. Hose neck | 25. AIRBELT bumper & textile cover |
| 12. Filter bag cover | |

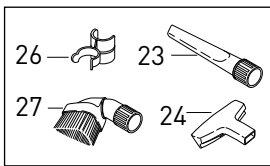
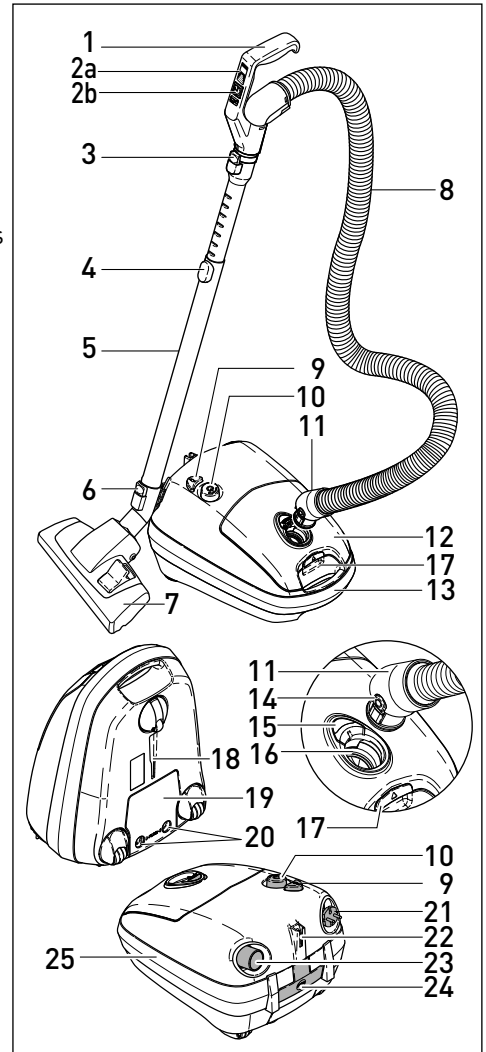

Standard Attachments

- | | |
|-----------------------|------------------------|
| 23. Crevice nozzle | 26. Dusting brush clip |
| 24. Upholstery nozzle | 27. Dusting brush |

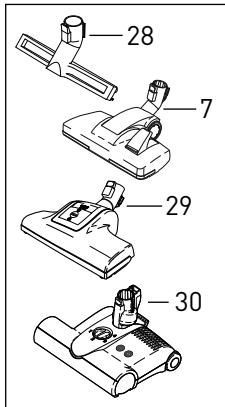

Brushes and Heads

- 28. Parquet Brush - standard for the E3 Premiums and E2 Turbo, optional for the E1 Kombi - Part #6391DA
- 7. Kombi Nozzle - standard for the E1 Kombi, optional for the E3 Premiums and E2 Turbo - Part #8351GS
- 29. TT-C Turbo Head - standard for the E2 Turbo, optional for the E3 Premiums and E1 Kombi - Part #8365GS
- 30. ET-1 Power Head - standard for E3 Premiums Arctic White - Part #9260AM; Red - Part #9296AM; Graphite - Part #9988AM; Black - Part #9961AM

ASSEMBLY

Push the neck (11) of the hose (8) into the suction opening of the canister (16).

E3: The three notches in the suction opening (32) will line up with the three prongs on the neck. When the notches are lined up correctly, the neck will snap firmly into place.

E1 & E2: The slot in the suction opening (31) will line up with the raised bar on the hose neck. When lined up correctly, the neck will snap firmly into place.

To release the hose from the suction opening, press release buttons (14) on the neck of the hose (11), and pull the neck out.

Connect the handle (1) to the top of the telescopic tube (5). Snap in place. To release the telescopic tube (5) from the handle, push the handle release button (3) and slide the handle out.

Attach the head or brush to the bottom of the telescopic tube (5). Insert the bottom of the telescopic tube into the neck (33) of the head or brush until it locks into place; or line up the square hole in the telescopic tube with the notches in the front of the neck, and snap firmly into place. To release a head or brush from the telescopic tube (5), push the release button (6), and pull the head or brush tool off the end of the telescopic tube. The release button (6) is in the same position on all of the heads, brushes and power heads.

To attach the dusting brush clip (26) - **E3:** Locate the two raised ridges on the upper end of the telescopic tube (5) just below the handle. Push the clip onto the tube directly below the ridges then slide the clip up until it locks onto the ridges. **E1 & E2:** Push the clip onto the tube and slide to desired position. Snap the dusting brush (27) into the holder.

NOTE: To attach the ET-1 Power Head to your E3 Premium, please refer to your power head owner's manual for instructions.

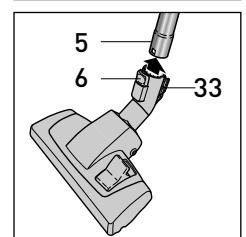
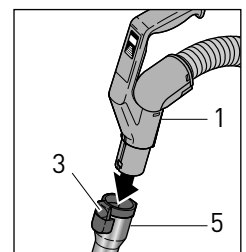
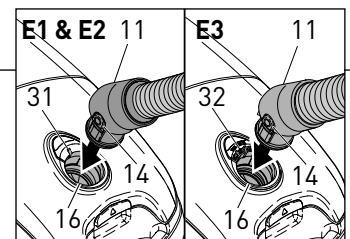

OPERATING INSTRUCTIONS

Starting The Machine

Your AIRBELT E canister is equipped with a soft start system and variable suction controls. To help you better understand the various power control options on your SEBO canister, please follow the instructions below.

E3 Premium Users - Figures 1, 2, 3 & 4

Before turning on your canister, make sure that the vacuum handle is in its upright locked position.

1. With the canister main power knob (10) in the OFF position, and the suction-control slider on the handle (#2a, figure 4) in the OFF position, pull the power cord out from the base of the canister (figure 1). The power cord should be unwound from the cable reel at least two thirds of its length.
Note: do not over-extend the cord.
2. Plug the polarized power cord into a 120 volt wall outlet located near the floor.
3. Press the main power knob (10) on the base of the canister gently with your foot or hand. A blue light will illuminate indicating that the power is on.
4. Slide the suction-control slider (#2a, figure 4) toward the MAX position. It will move freely between 0 suction and MAX suction. Set the slider to the suction desired.
5. When the power head is on with the handle in the upright locked position, the brush roller will not spin. To release the ET-1 power head from the upright locked position, press down on the foot pedal, (#34, figure 3), lower the handle into the normal operating position and push the brush roller switch on the handle (#2b, figure 4) to engage the brush roller. The green light on the power head will illuminate. The handle can be lowered to a horizontal position useful for vacuuming under beds.

Note: E3 users - see the ET-1 Owner's Manual for power head instructions.

E1 Kombi and E2 Turbo Users - Figures 1 & 2

Before turning on your canister, make sure that the vacuum handle is in its upright locked position.

1. With the canister main power knob (10) in the OFF position, pull the power cord out from the base of the canister (figure 1). The power cord should be unwound from the cable reel at least two-thirds of its length. **Note:** do not over-extend the cord.
2. Plug the polarized power cord into a 120 volt wall outlet located near the floor.
3. Press the main power knob (10) on the base of the canister gently with your foot or hand.

Suction Control

E3 Premium Users - Figure 4

You may adjust the suction with the suction-control slider (2a) as you vacuum different surfaces or when using the accessory tools. For optimal cleaning and brushing, operate the machine at the maximum suction power setting and push the power head slowly over the carpet.

When the canister's main power knob (10) is in the ON position, you may turn the suction and the power head off and on with the suction-control slider (2a). To turn the power off using the suction-control slider, pull the slider to 0 suction, then continue pulling the slider up until it "clicks" into the OFF position. The green power head light will then shut off (the blue light on the canister will remain illuminated until the vacuum is powered off using the main power knob).

E1 Kombi and E2 Turbo Users - Figure 5

The on/off power and suction-control knob is located on the top side of the canister (10). Rotate the knob clockwise for maximum suction. Rotate counter-clockwise to reduce suction for vacuuming curtains or delicate fabrics.

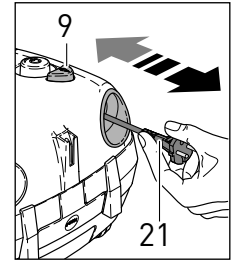

Figure 1

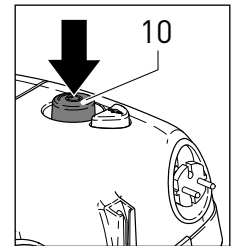

Figure 2

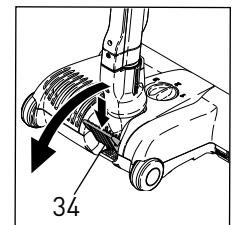

Figure 3 - E3

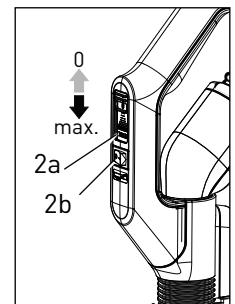

Figure 4 - E3

0 = Zero Suction
MAX = Maximum Suction
ON position - Move the slider toward MAX.
OFF position - Pull the slider up to 0 suction then continue pulling the slider up until it "clicks" into the OFF position.

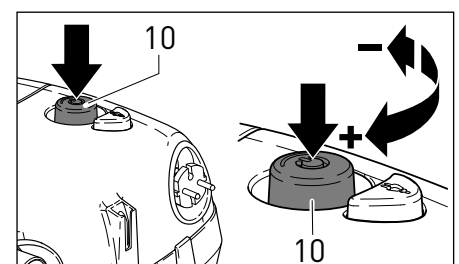

Figure 5 - E1 & E2

Brush Roller Switch - E3 Premium - Figure 6

To switch from brushing action to straight suction for delicate floors, press the brush roller power switch (2b) on the handle. This will power off the brush roller on the power head. All indicator lights on the power head will turn off until the brush roller button is switched on again.

Adjusting the Telescopic Tube - Figure 7

Adjust the telescopic tube (5) to the correct height by pushing the slide button (4) and gently pulling the tube out to lengthen, or pushing it in to shorten. Release the slide button (4) to lock the tube to the adjusted height.

Using the Telescopic Tube, Hose & Attachments - Figures 8, 9, 10, 11 & 12

ALWAYS TURN OFF THE CANISTER AND UNPLUG BEFORE CONNECTING OR DISCONNECTING THE HOSE (8), TELESCOPIC TUBE (5) OR POWER HEAD.

The telescopic tube (5) is useful for vacuuming corners and hard-to-reach areas. You may use the telescopic tube without a brush, power head or attachment. To remove a brush or power head, switch off the power knob (10) and unplug the vacuum. Then, press the tool release button (6) and pull the tube out. The crevice nozzle (23) and dusting brush (27) may be inserted onto the end of the tube. To use the upholstery nozzle (24), fit it onto the end of the crevice nozzle (23). It is not necessary to turn off the vacuum while switching the **standard** attachments (the crevice nozzle, upholstery nozzle or dusting brush). After use, switch off the power, unplug the vacuum and remove attachment. Re-insert the telescopic tube into the power head or brush, turning the tube if needed, until you hear it click into place.

To use the hose without the telescopic tube, switch off the power and unplug the vacuum. Push the handle release button (3) and pull the HANDLE out of the end of the telescopic tube. Do not try to separate the hose from the handle! Insert the crevice nozzle (23) or dusting brush (27) onto the end of the handle. To use the upholstery nozzle (24), fit it onto the end of the crevice nozzle (23). After use, switch off the power, unplug the vacuum and remove the attachment. Re-insert the handle into the telescopic tube making sure it is seated correctly and snap it into place.

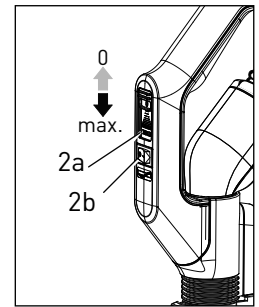

Figure 6 - E3

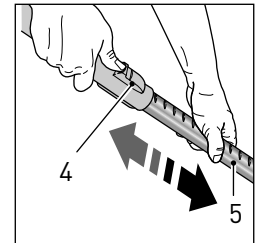

Figure 7

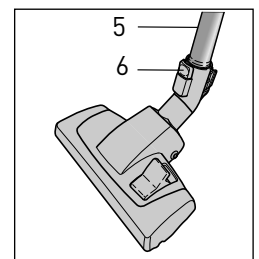

Figure 8

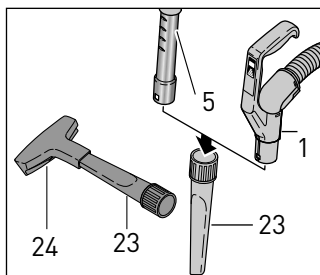

Figure 10

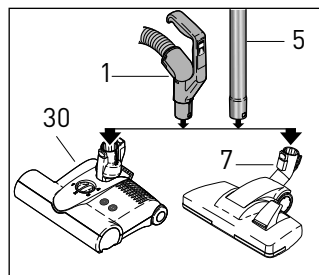

Figure 11

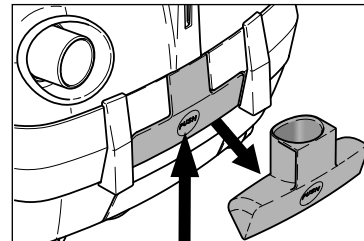

Figure 12- Push button to release upholstery nozzle.

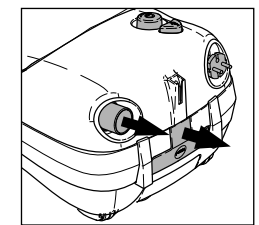

Figure 9

Bag Full or Clog Indicator & Auto Shut-Off - Figure 13

When the "BAG FULL OR CLOG" indicator, located on top of the canister (15), illuminates, airflow is reduced due to a full bag, a clog in the airflow pathway, or an excessively dirty filter. Turn the power off, unplug the machine and immediately insert a new bag (see page 12) or remove the clog (see page 14).

If the user ignores the warning indicator, the motor will shut off to protect itself from damage. The user should turn the power off, unplug the machine and immediately insert a new bag or remove the clog. If the airflow is still restricted, the "BAG FULL OR CLOG" indicator will illuminate again and the machine will shut off.

Vacuuming fine dust may require an earlier filter bag change even though the filter bag is not full. Fluff may overflow the bag without the light coming on.

The bag full indicator works more efficiently at full power. Check the bag full status regularly at full suction power.

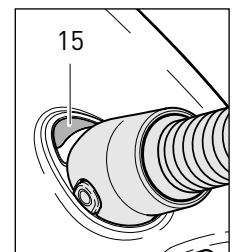

Figure 13



WARNING!

The quality, condition, coating, texture, age and manufacturing technique of all floor surfaces vary. Therefore, vacuums with rotating brushes, including your SEBO, may damage some floor coverings or surfaces. Some types of high-gloss hardwood floors, cushion vinyl, berber carpets, long shag, and delicate or hand-woven carpets are particularly vulnerable to damage by rotating brushes. When possible, consult the materials supplied by your flooring manufacturer for information on proper upkeep and cleaning. **To ensure that your new SEBO vacuum cleaner is compatible with your floor, please test the vacuum cleaner on each type of flooring surface in a small inconspicuous area to determine if any damage occurs. If damage occurs, stop using the vacuum cleaner immediately!**

Retracting the Cord - Figure 14

To retract the cord, switch the vacuum off, unplug it from the outlet, then press the push-button cord retractor (9) and the mechanism will automatically rewind the cord. You must hold the button down until the cord is fully rewound. Hold plug while rewinding into the cord wheel. Do not allow the plug to whip while rewinding. The rewind mechanism will stop automatically when you release the button. Before rewinding the cord, always switch off and unplug the vacuum.

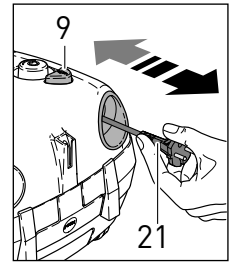

Figure 14

ALWAYS TURN THE POWER OFF ON THE CANISTER BEFORE UNPLUGGING THE UNIT.

Storing the Vacuum- Figure 15

The vacuum can be stored with the canister in a horizontal or vertical position. The Parquet Brushes, Kombi Nozzles and the TT-C Turbo Head have a parking tab located on the neck (35). Insert the parking tab into the upper side of the parking groove (18 or 22) and slide down firmly. For vertical storage, or for easy carrying, use the parking groove on the underside (18). For horizontal storage, use the parking groove on the end of the canister (22).

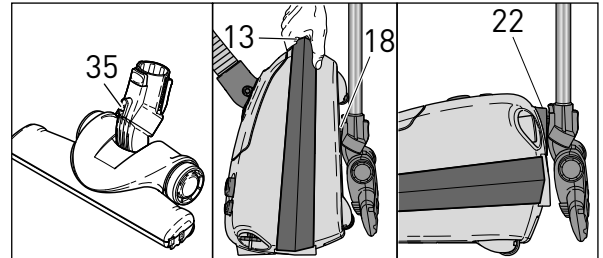

Figure 15

USE AND MAINTENANCE OF BRUSHES AND HEADS

⚠ Always unplug vacuum from outlet before dismantling any part of machine! To remove a brush or power head, switch off the power and unplug the vacuum. Then, press the tool release button (6) and pull the tube out.

NOTE! E3 Premium users with the ET-1 power head, please refer to your power head user's manual for more detailed instructions for operating and maintaining your power head.

Parquet Brush - Figure 16

The Parquet Brush (28) was designed specifically for vacuuming hard floors. It is lightweight with soft bristles, so it glides gently over floors and provides easy maneuverability. Fibers and hair can be pulled out of the bristles manually, or vacuum the bristles with the telescopic tube.

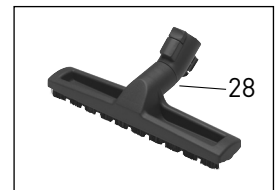

Figure 16

Premium Parquet Brush - Figure 17

The Premium Parquet Brush (36) is specially designed for use on hard surfaces. The brush should be cleaned regularly. Remove the parquet brush from the telescopic tube to clean. Fibers and hair can be pulled out of the bristles manually, or vacuum the bristles with the telescopic tube. The brush strips are removable for cleaning and replacement.



Figure 17

TT-C Turbo Head - Figure 18

The TT-C Turbo Head (29) has an air-driven rotating brush for gentle brushing of carpets. The Turbo head can be adjusted for high and low pile carpet. To adjust the head for high pile carpet, push the slider button (37) upward. For low pile carpet, push the slider button (37) downward. The rotating brush should be cleaned regularly. Remove the Turbo head from the telescopic tube to clean. Remove fibers and hair from the brush manually.

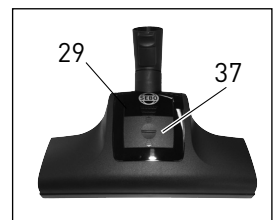

Figure 18

Kombi Nozzle and Premium Kombi Nozzle - Figure 19

The Kombi Nozzle (7) and the Premium Kombi Nozzle (38) are adjustable for carpet or hard floors. Use the toggle button (39) on either nozzle to raise the brush for carpet or lower the brush for hard floors. The brush should be cleaned regularly. Remove the nozzle from the telescopic tube to clean. Fibers and hair can be pulled out of the bristles manually, or vacuum the bristles with the telescopic tube.

NOTE: The Premium Parquet Brush and the Premium Kombi Nozzle have brush strips that are removable for cleaning and replacement. To change the brush strip, remove the yellow cap with a screwdriver and pull out the brush strip. After inserting the new brush strip, the cap has to click into place again.

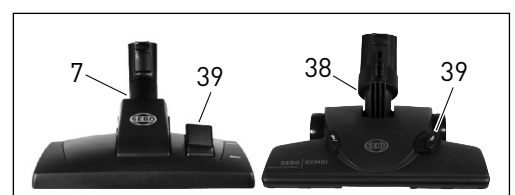

Figure 19

VACUUM MAINTENANCE

⚠ Always unplug vacuum from outlet before dismantling any part of machine!

Changing the Filter Bag - Figures 20, 21 & 22

To change the filter bag (40), lift the filter bag release catch (17, figure 20) then lift open the filter bag cover (12). Seal the used filter bag with the sealing cap (41). Tilt the green sealing plate collar up (42, figure 21) and lift the bag out. Slide the front of the sealing plate (42) of a new bag vertically into the bag holder (43, figure 22). Line up the sealing plate so that the U-shaped metal spring (44) is positioned in the slot (44) of the collar and tilt it back into place. Close the cover, making sure it snaps shut completely. The cover will not close if the bag is inserted improperly. Do not re-use the filter bags. **Note:** The nature of the contents of the filter bag will affect the point at which it needs changing. Fine dust may require an earlier change even though the bag is not full. Fluff or hair allows air to pass through easily, so the filter bag may overfill before the “bag full” indicator turns orange.

The “bag full or clog” indicator works correctly only at full power. At lower power levels, the “bag full or clog” indicator may read incorrectly. Check the status of the filter bag regularly at full power.

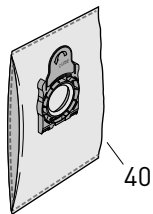

AeraPure™ Filter Bags
Part #8300AM

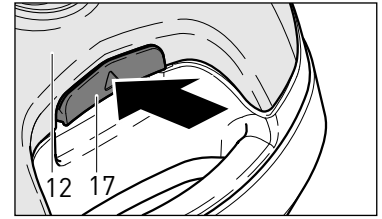

Figure 20

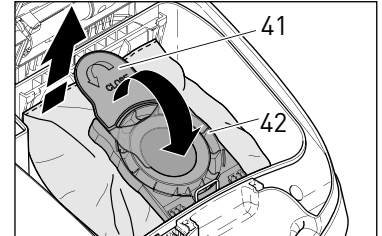

Figure 21

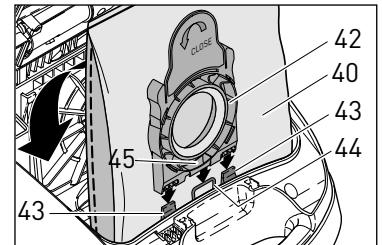
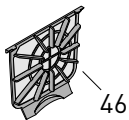

Figure 22

Changing the Pre-motor Filter - Figure 23

The pre-motor filter (46) needs to be changed when it becomes extremely dirty or clogged with dust, or after approximately 10 to 20 filter bags have been used. To change the pre-motor filter, lift the filter bag release catch (17, figure 20), lift open the filter bag cover (12) and remove the filter bag. Grasp the tab at the bottom of the filter (47, figure 23) and pull the filter out and up. When the filter is horizontal, lift it out of the holder (48). Insert the new filter into the holder horizontally (48) then swing it downward until the tab (47) locks into place. Replace the filter bag and the filter bag cover.



Pre-motor Filter
part of the E Filter Set
Part #8322AM

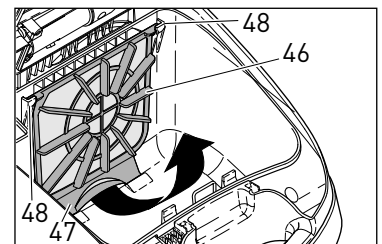
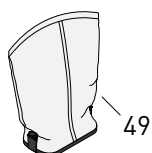

Figure 23

Changing the Exhaust Microfilter - Figures 24, 25 & 26

After 10 to 20 bags have been used, change the exhaust microfilter (49). To remove the exhaust microfilter, press the filter cover release buttons together (20, figure 24) and pull the filter cover (19) off. Pull the material part of the filter out of the machine (49, figure 25). Press the red latches (50, figure 26) located on either side of the filter inward and pull the filter out. Insert the opening of the new filter over the exhaust opening with the red alignment tab at the bottom. When it is aligned, push down until the red latches (50) click shut to hold the filter in place. Tuck the material part of the filter inside the opening. Insert the cover by fitting the tabs on the top side of the cover into the grooves. Push the cover closed, making sure it snaps shut completely.



Exhaust Microfilter
part of the E Filter Set
Part #8322AM

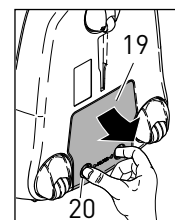

Figure 24

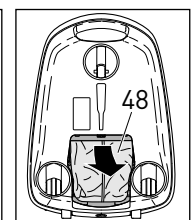

Figure 25

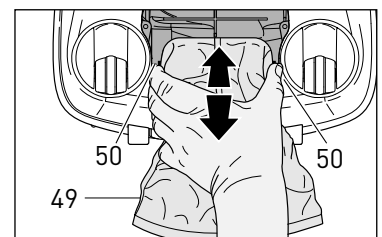

Figure 26

Note: Never operate the vacuum with incorrectly attached filters or without filters, bag, AIRBELT textile or filter bag housing cover (26). Do not re-use filter bags. Do not wash and re-use filters.

Changing the AIRBELT Textile - Figures 27-33

Your E-Series vacuum cleaner is fitted with the patented AIRBELT shock absorber system, which protects your walls and furniture and filters exhaust air. The AIRBELT shock absorber system consists of the foam bumper (52) and the AIRBELT textile cover (25). If damage occurs to the AIRBELT textile, it will need to be replaced.

To remove the AIRBELT system (25 & 52), remove the upholstery tool from the rear of the machine (figure 27), and lever out the tool holder (51) using a slot-head screwdriver (figure 28). The AIRBELT system (25 & 52) can then be pried out of the recess with a screwdriver (figure 29) and removed by carefully sliding the assembly toward the front of the machine (figure 30). Remove the damaged textile (25) from the foam bumper (52).

Fit the new AIRBELT textile (25) over the foam bumper (52) by inserting the side rails (53, figure 31) of the textile (25) into the grooves (54) of the foam bumper. The upper side rail of the textile has a mark (55, figure 31). Insert the upper side rail with the mark into the groove which is marked "TOP" (56, figure 31). Start from one end and continue fitting the textile into the grooves around the bumper (figure 32). Fit the bumper assembly to the front of the machine, then press in around the sides toward the rear (figure 33).

Refit the upholstery tool holder (51) under the parking groove (22) and tilt it down to lock it into the lower side. Finally, re-insert the upholstery tool.

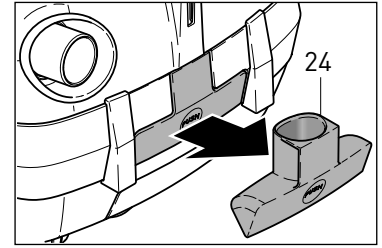

Figure 27

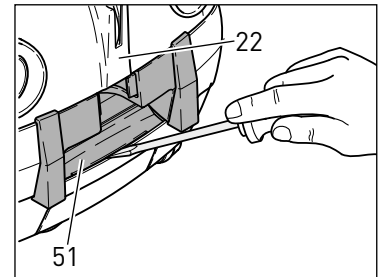

Figure 28

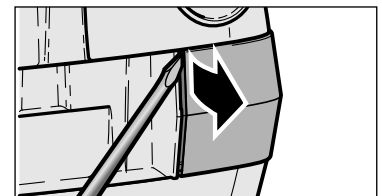
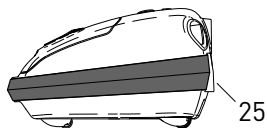

Figure 29



AIRBELT Textile
Part #8221AM01 - Gray Black, solid
Part #8221AM10 - Black/Silver, stripes,

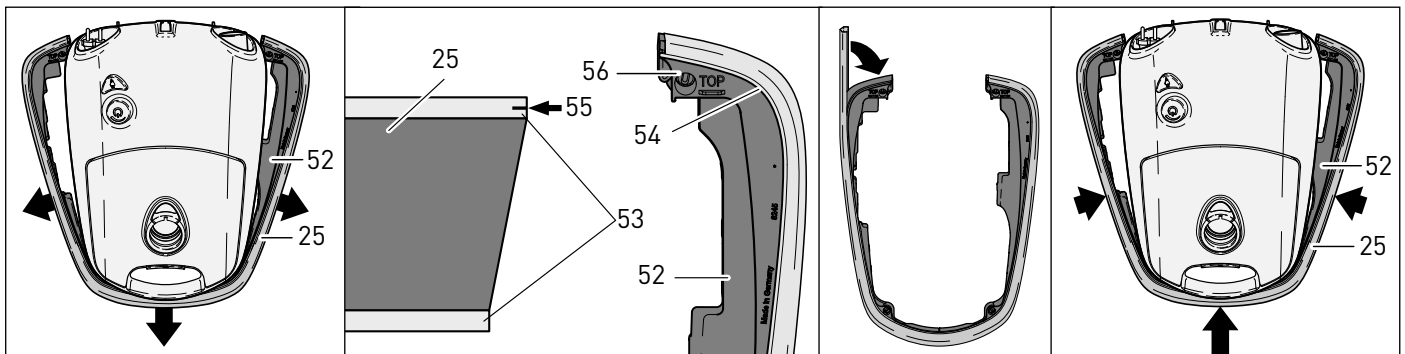

Figure 30

Figure 31

Figure 32

Figure 33

Note: Never operate the vacuum with incorrectly attached filters or without filters, bag, AIRBELT textile or filter bag housing cover (12). Do not re-use filter bags. Do not wash and re-use filters.

CLOG REMOVAL

! Always unplug vacuum from outlet before removing any clogs!

NOTE! E3 users with ET-1 power heads, please refer to your power head user's manual for more detailed instructions for removing clogs in your power head.

If the "bag full or clog" warning indicator (15) remains orange after the filter bag has been changed and the filters are in good condition, there is likely a clog in the system.

Clogs in the Head or Brush - Figure 34

Clogs in the swivel neck (56) of a head or brush can be cleared by first pressing the tool release button (6) and removing the brush or head. Check inside the swivel neck channel, and clean out pathway.

Clogs in the Telescopic Tube - Figure 34

Remove head from telescopic tube (5) by pushing the tool release button (6) and pulling the tube out. Remove the hose from the top of the telescopic tube by pushing the handle release button (3). A stiff wire or stick can be used to push the clog out of the tube.

Clogs in the Hose - Figures 35, 36 & 37

Check for suction at the handle end of the hose. If you feel reduced suction, the blockage is in the hose. To clear blockages in the hose (8), remove the handle (1) from the telescopic tube by pressing the handle release button (3). Hold the hose upright with one hand blocking the end of the handle (figure 36) and switch on the machine at full power. If necessary, quickly lift your hand on and off the end of the hose.

Note: Do not insert a wire or stick into the hose. Doing so may cause damage to the hose.

Clogs in Entrance to Filter Bag - Figures 38 & 39

Remove hose (10) from vacuum cleaner. To release the hose from the suction opening, press release buttons (14) on the neck of the hose (11), and pull the neck out. Check the hose neck (11) and suction opening (16) for clogs. If the clog is in the filter bag opening, open the filter bag cover and clean out the entrance to the bag (57).

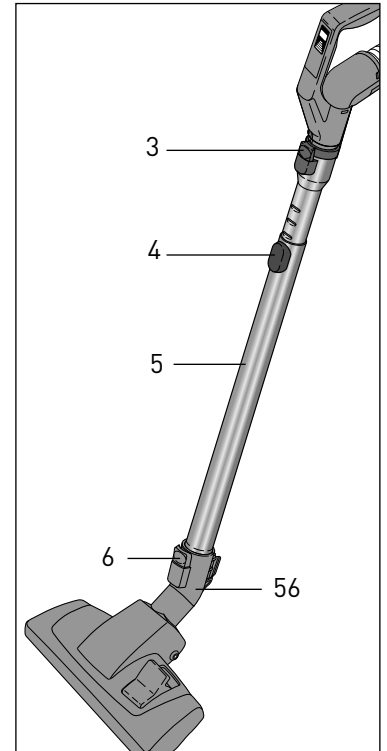

Figure 34

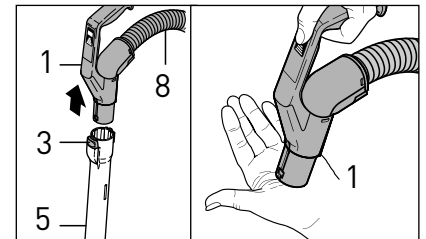

Figure 35

Figure 36

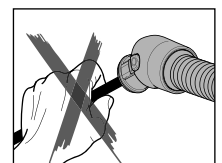

Figure 37

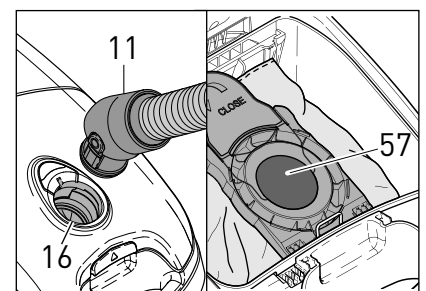

Figure 38

Figure 39

TROUBLE-SHOOTING GUIDE



Always unplug vacuum from outlet before dismantling any part of the machine!

PROBLEM	REASON	SOLUTION
Does not turn on	1. Telescopic tube not inserted properly.	1. See page 7.
	2. Not plugged into working outlet.	2. Use another outlet.
	3. Cord worn.	3. Replace cord.
	4. Hose neck (11) not inserted properly into suction opening (16).	4. See Assembly on page 7.
	5. E3: The suction-control slider switch is set to "0" ("off" position).	5. E3: Set slider switch to "on" position. See page 9.
Bag full or clog light on Bag full or clog light on & machine shuts off	1. Bag full.	1. Replace filter bag. See page 12.
	2. Clog in hose, telescopic tube, brush or head, or entrance to filter bag.	2. See Clog Removal on page 14. E3 users with clog in power head attachment: Refer to clog removal in the ET-1 owner's manual.
	3. Exhaust microfilter dirty.	3. Replace exhaust microfilter. See page 12.
	4. Pre-motor filter dirty.	4. Replace filter. See page 12.
Does not pick up	1. Hose/handle assembly not correctly inserted.	1. Re-insert hose/handle assembly making sure that it is lined up properly and is snapped into place. See page 7.
	2. The suction-control dial is rotated to no suction setting	2. E1 & E2: Rotate suction-control dial clockwise for suction. See page 9.
	3. Filter bag cover not closed.	3. See below.
Filter bag door won't fully close	1. Filter bag cover not fully closed.	1. Re-insert bag. Lock the cover down firmly.
	2. Bag not inserted properly	2. Re-insert bag. Lock the cover down firmly.
	3. Pre-motor filter not properly inserted.	3. Remove the filter bag and make sure the pre-motor filter is seated firmly in place (see pg. 12, figure 23).

AIRBELT E1 KOMBI AND E2 TURBO SCHEMATIC AND PARTS LIST

- #91602AM AIRBELT E1 Kombi - Arctic White (USA)
- #91602FC AIRBELT E1 Kombi - Arctic White (Canada)
- #91604FC AIRBELT E1 Kombi - Black (Canada)
- #91620AM AIRBELT E2 Turbo - Dark Blue (USA)
- #91620FC AIRBELT E2 Turbo - Dark Blue (Canada)
- #91621FC AIRBELT E2 Turbo - Red (Canada)

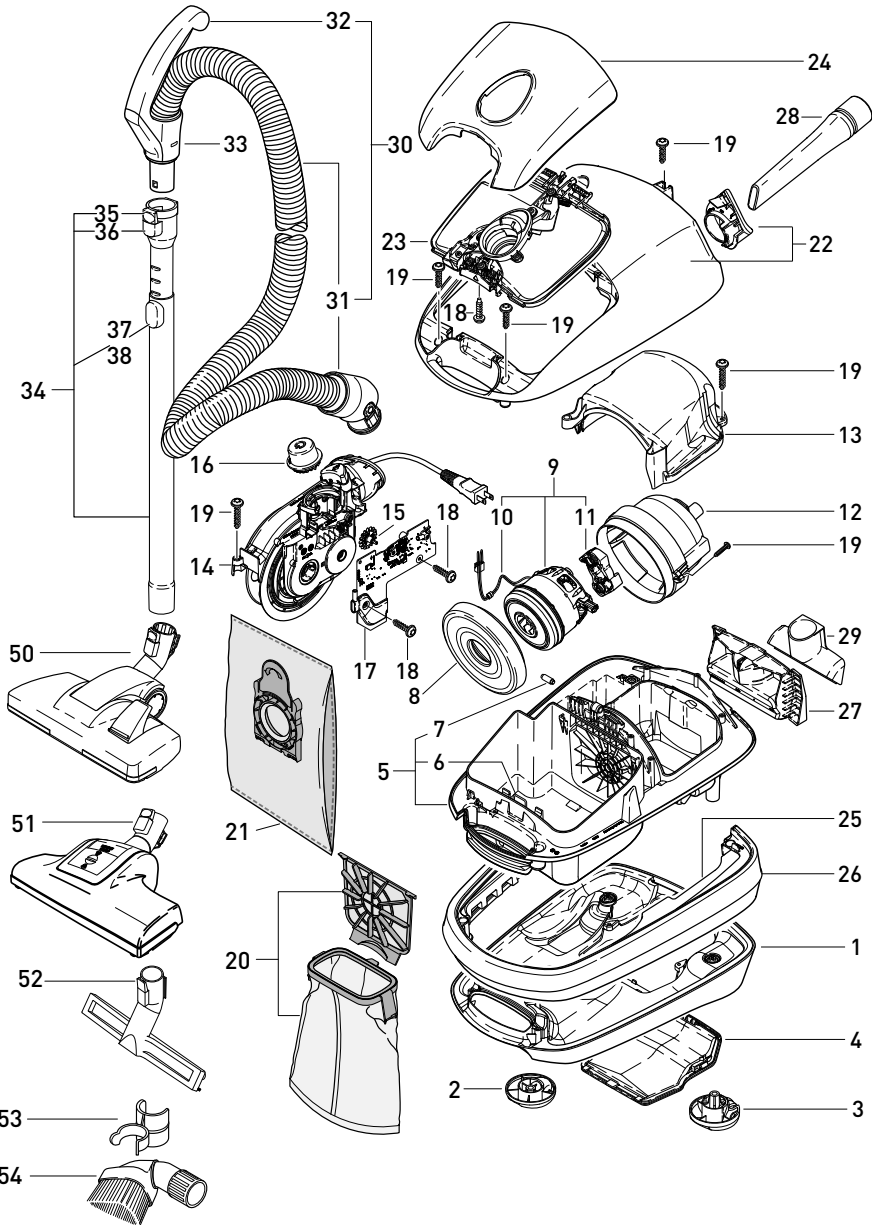

Canister with Handle/Hose

#91602AM E1 Kombi, #91602FC E1 Kombi Arctic White Machine

Pos.	Part #	Description
1	8335WEER	Bottom casing, white
2	8275GSER	Castor front, gray black
3	8276GSER	Castor rear, gray black
4	8249WEER	Cover exhaust air filter, white
5	8230ULER	Middle casing incl. pos. 6+7
6	7045ER	Cover latch spring
7	8053ER	Bolt 20 x 5/7
8	8212ER	Engine mount gasket
9	8243ER	Vac motor 120 V
10	8282ULER	Wire
11	8045ER	Motor support
12	8220ER	Noise limiting cover
13	8289ER	Motor cover
14	665633ER	Cord rewind unit, AM plug
15	8256ER	Potentiometer pinion
16	8338ER	On/Off button E1 & E2, cpl.
17	8292ER	Printed circuit board
18	01036	Screw 4 x 14
19	01017	Screw STS 4 x 20 T20
20	8322AM	Microfilter box E - microfilter filter and exhaust microfilter
21	8300AM	AeraPure™ filter bags E
22	8328WEER	Top casing, white
23	8340ER	Top cover E1, inner part
24	8224WEER	Filter cover
25	8237ER	Bumper
26	8221AM01	AIRBELT Textile, gray black, solid, AM models
	8221AM10	AIRBELT Textile, black/silver, stripes, FC models
27	8213GSER	Support
28	8066GS	Crevice nozzle
29	8210GS	Upholstery nozzle
30	8310	Hose cpl. incl. handle
31	8314	Hose E1 and E2, without handle
32	6300GS	Handle grip, cpl., without hose
33	6303GS	Retaining ring
34	6237ER	Telescopic tube (incl. 6668GS dusting brush clip adapter)
35	1736GS	Fitting neck
36	1735ER	Release button, cpl.
37	6238ER	Locking mechanism
38	6425ER	Sliding knob
50	8351GS	Kombi Nozzle, gray black
53	6694GS	Dusting brush clip, gray black
54	1387GS	Dusting brush

#91604FC E1 Kombi - Black Machine Exceptions

1	8335SWER	Bottom casing, black
4	8249SWER	Cover exhaust air filter, black
22	8328SWER	Top casing, black
24	8224SWER	Filter cover, black

#91620AM E2 Turbo, #91620FC E2 Turbo Dark Blue Machine Exceptions

1	8335DBER	Bottom casing, dark blue
4	8249DBER	Cover exhaust air filter, dark blue
22	8328DBER	Top casing, dark blue
24	8224DBER	Filter cover, dark blue
51	8365GS	TT-C Turbo Head
52	6391DA	Parquet Brush

#91621FC E2 Turbo - Red Machine Exceptions

1	8335DRER	Bottom casing, red
4	8249DRER	Cover exhaust air filter, red
22	8328DRER	Top casing, red
24	8224DRER	Filter cover, red
51	8365GS	TT-C Turbo Head
52	6391DA	Parquet Brush

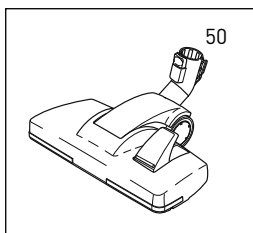

Kombi Nozzle
included with E1 Kombi
#8351GS

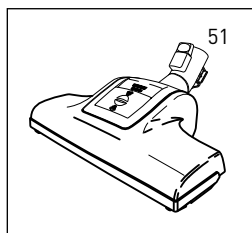

TT-C Turbo Head
included with E2 Turbo
#8365GS

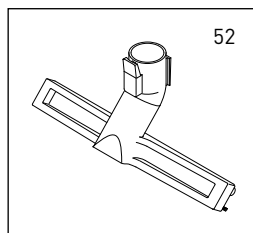

Parquet Brush
included with E2 Turbo
#6391DA

AIRBELT E3 PREMIUM SCHEMATIC AND PARTS LIST

- #91646AM AIRBELT E3 Premium - Arctic White (USA)
- #91646FC AIRBELT E3 Premium - Arctic White (Canada)
- #91647AM AIRBELT E3 Premium - Red (USA)
- #91647FC AIRBELT E3 Premium - Red (Canada)
- #91648AM AIRBELT E3 Premium - Graphite (USA)
- #91648FC AIRBELT E3 Premium - Graphite (Canada)
- #91650AM AIRBELT E3 Premium - Black (USA)

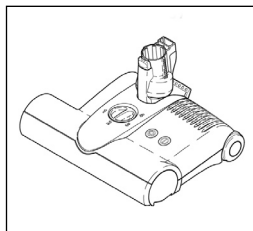
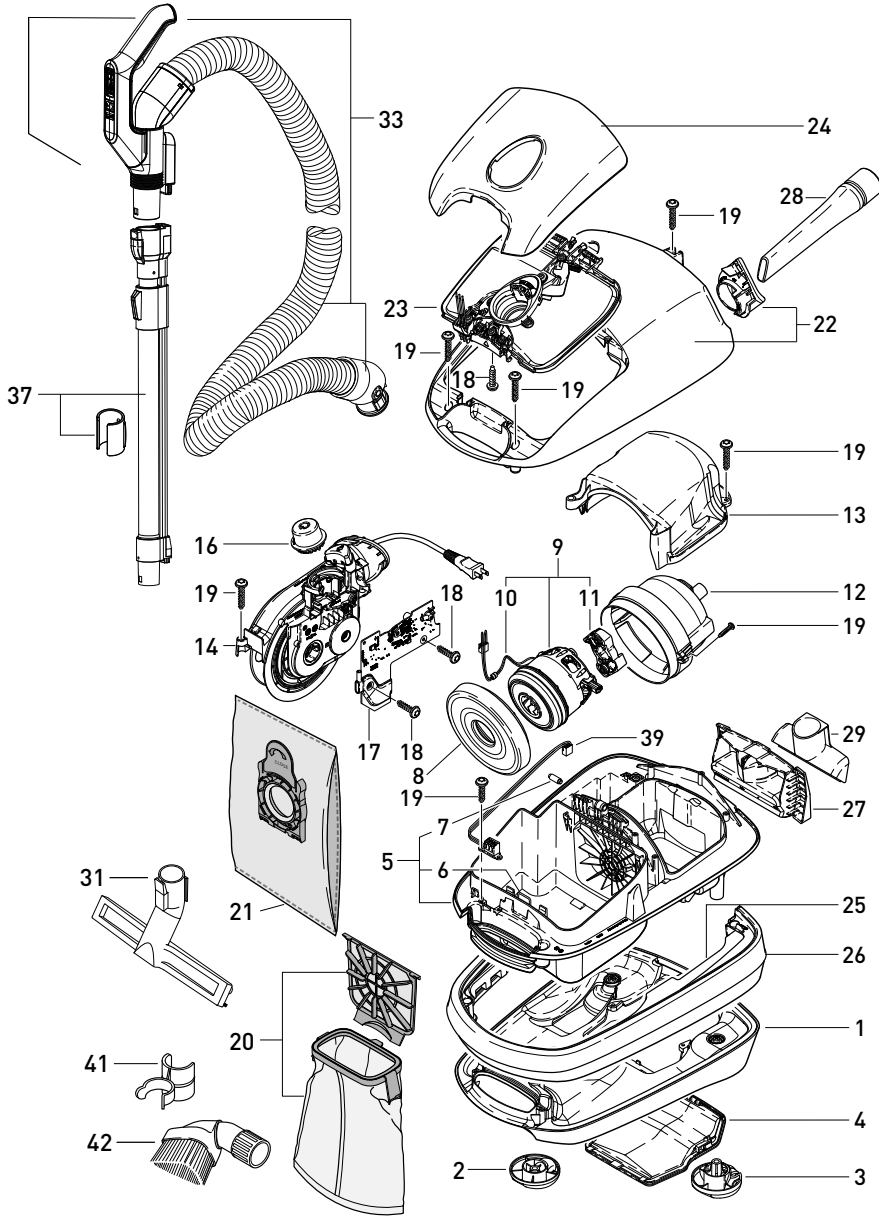

ET-1 Power Head
included with E3 Premium
Refer to ET-1 Manual for parts
identification

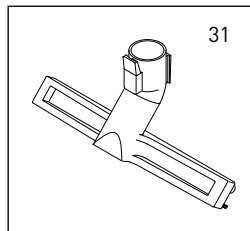

Parquet Brush
included with E3 Premium
#6391DA

Canister with Handle/Hose

#91646AM, #91646FC E3 Premium Arctic White Machine

Pos.	Part #	Description
1	8335WEER	Bottom casing, white
2	8275GSER	Castor front, gray black
3	8276GSER	Castor rear, gray black
4	8249WEER	Cover exhaust air filter, white
5	8230ULER	Middle casing incl. pos. 6+7
6	7045ER	Cover latch spring
7	8053ER	Bolt 20 x 5/7
8	8212ER	Engine mount gasket
9	8243ER	Vac motor 120 V
10	8282ULER	Wire
11	8045ER	Motor support
12	8220ER	Noise limiting cover
13	8289ER	Motor cover
14	665633ER	Cord rewriter
16	8339ER	On/Off button E3, cpl.
17	8296ER	Printed circuit board
18	01036	Screw 4 x 14
19	01017	Screw STS 4 x 20-T20
20	8322AM	Filter box E - pre-motor filter and exhaust microfilter
21	8300AM	AeraPure™ filter bags E
22	8328WEER	Top casing, white
23	8341ER	Top cover E3, inner part
24	8224WEER	Filter cover, white
25	8237ER	Bumper
26	8221AM01	AIRBELT Textile, gray black, solid
27	8213GSER	Support
28	8066GS	Crevice nozzle
29	8210GS	Upholstery nozzle
31	6391DA	Parquet Brush
33	8547AM	7' hose & handle for E3, complete assembly only
37	60237UC	Telescopic tube (incl. 60238AD dusting brush clip adapter)
39	8320ER	Cabling set
41	6694GS	Dusting brush clip
42	1387GS	Dusting brush

#91647AM, #91647FC E3 Premium Red Machine Exceptions

1	8335DRER	Bottom casing, red
4	8249DRER	Cover exhaust air filter, red
22	8328DRER	Top casing, red
24	8224DRER	Filter cover, red

#91648AM, #91648FC E3 Premium Graphite Machine Exceptions

1	8335GSER	Bottom casing, gray black
4	8249GSER	Cover exhaust air filter, gray black
22	8328GSER	Top casing, gray black
24	8224GSER	Filter cover, graphite
26	8221AM10	AIRBELT Textile, black/silver, stripes

#91650AM E3 Premium

Black Machine Exceptions

1	8335SWER	Bottom casing, black
4	8249SWER	Cover exhaust air filter, black
22	8328SWER	Top casing, black
24	8224SWER	Filter cover, black
26	8221AM10	AIRBELT Textile, black/silver, stripes

NOTES