



MADE IN GERMANY

SEBO AIRBELT K

OWNER'S MANUAL

For Household Use Only

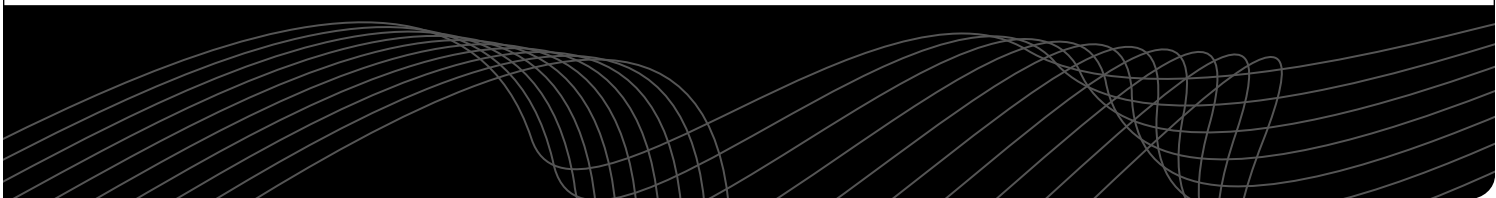

TABLE OF CONTENTS

Technical Details	2
How To Contact SEBO	2
Important Safety Instructions	3
AIRBELT K Product Features	4
AIRBELT K2 Turbo and AIRBELT K2 Kombi Features	5
AIRBELT K3 Premium Features	5
Optional Attachments, Accessories, Bags and Filters	6
Standard Features of All SEBO Vacuums	7
Identification of Parts	8
Standard Attachments	8
Brushes and Heads	8
Assembly	8
Operating Instructions	9
Starting the Machine	9
Suction Control	9
Brush Roller Switch (K3 Premium).....	10
Adjusting the Telescopic Tube	10
Using the Telescopic Tube, Hose & Attachments.....	10
Bag Full or Clog Indicator & Automatic Shut-off.....	10
Retracting the Cord	11
Storing the Vacuum	11
Use and Maintenance of Brushes and Heads	11
Parquet Brush	11
Premium Parquet Brush.....	11
Turbo TT-C Head	11
Kombi Nozzle	11
Premium Kombi Nozzle.....	11
Vacuum Maintenance	12
Changing the Filter Bag	12
Changing the Exhaust Filter.....	12
Changing the Pre-motor Microfilter.....	12
Changing the AIRBELT Textile.....	12
Clog Removal	13
Clogs in the Head or Brush.....	13
Clogs in the Telescopic Tube.....	13
Clogs in the Hose	13
Clogs in Entrance to Filter Bag.....	13
Trouble-shooting Guide	14
AIRBELT K2 Turbo and AIRBELT K2 Kombi Schematic and Part Numbers	15
AIRBELT K3 Premium Schematic and Part Numbers	16

TECHNICAL DETAILS

Vacuum motor	1250 watts (10.6 amps)	Body weight	12 lbs.
Water lift (at motor)	95 inches	Motor protection	thermal cut-out
Airflow (at motor)	120 CFM	Cord length	25 feet
Filter bag capacity	.8 gallons	Range	37 feet
Sound level	63 dBA		

Technical details may be subject to change.

HOW TO CONTACT SEBO

To contact SEBO in the United States of America:

SEBO America, LLC
 Telephone: (800) 334-6614
 Fax: (303) 792-9196
 Website: www.sebo.us

To contact SEBO in Canada:

SEBO Canada
 Telephone: (877) 258-5005
 Fax: (800) 270-4807
 Website: www.sebocanada.ca

IMPORTANT SAFETY INSTRUCTIONS



READ ALL INSTRUCTIONS BEFORE USING THIS MACHINE

When using an electrical appliance, basic precautions must always be followed.

To reduce the risk of electric shock, this vacuum cleaner has a polarized plug; one blade is wider than the other. This plug will fit in a polarized outlet only one way. If the plug does not fit fully in the outlet, reverse the plug. If it still does not fit, contact a qualified electrician to install the proper outlet. Do not change the plug in any way. Connect only to the outlet type specified on the serial number plate underneath the machine.

SAVE THESE INSTRUCTIONS.

WARNING: To reduce the risk of fire, electric shock, or injury:

1. Do not leave vacuum while plugged in. Unplug from outlet when not in use and before servicing.
2. Do not use outdoors or on wet surfaces.
3. Do not use near small children or pets. Do not allow to be used as a toy. Use of this product by children should always be supervised by an adult.
4. Use only as described in this manual. Use only manufacturer-recommended attachments.
5. Do not use with a damaged cord or plug. If vacuum is not working as it should, has been dropped, damaged, left outdoors, or dropped into water, take it to a SEBO service center.
6. Do not pull or carry by cord, use cord as a handle, close a door on cord, or pull cord around sharp edges or corners. Do not run vacuum over cord. Keep cord away from heated surfaces.
7. Do not unplug by pulling on cord. To unplug, grasp the plug – not the cord.
8. Do not use outlets above counters to plug in vacuum – damage to items in the surrounding area could occur.
9. Always carry the vacuum over steps and sills.
10. Do not handle plug or vacuum handle with wet hands.
11. Do not put any object into vacuum openings. Do not use machine with any openings blocked. Keep openings free of lint, hair, and anything that may reduce air flow.
12. Do not re-use filter bags or wash the filters.
13. Do not remove any screws from vacuum.
14. Do not vacuum up anything that is burning or smoking, such as cigarettes, matches, or hot ashes.
15. Do not use vacuum without filter bag and/or filters in place.
16. Turn off all machine controls before unplugging.
17. Use extra care when cleaning on stairs.
18. Do not use machine to vacuum up flammable or combustible liquids such as gasoline or use in areas where they may be present.
19. Machines can cause a fire when operated near flammable vapors or materials. Do not operate this vacuum near flammable fluids, dust or vapors.
20. Maintenance and repairs must be done by authorized personnel.
21. Use only original SEBO replacement parts.
22. Do not use vacuum as a step.
23. If vacuum is used on plush carpet or carpet with thick padding, do not leave machine standing in one place with machine turned on.
24. While the vacuum is in use, the power cord should be unwound from the cable reel at least two thirds of its length. Hold plug when rewinding onto the cord reel. Do not allow plug to whip while rewinding.
25. Keep hair, loose clothing, fingers, and all parts of body away from vacuum openings and moving parts. Do not place fingers or other body parts under vacuum unless it is unplugged.
26. Do not place the power head over rug or carpet edges.
27. The vacuum has a manual reset thermal protector. The protector is reset by switching off the vacuum. The thermal protector needs some time to cool down after switching off! Check the vacuum for air blockages or mechanical failures before switching on.
28. Store the vacuum in a dry place at room temperature. When the vacuum is not in use, you should rewind the cord onto the cord reel.
29. The K3 hose contains electrical wires. Do not use if damaged, cut, or punctured. Avoid picking up sharp objects.
30. Always unplug vacuum before connecting or disconnecting either hose or power head.
31. Use a SEBO power head only in combination with a SEBO vacuum cleaner.
32. Do not connect power head to a malfunctioning or damaged vacuum.

SEBO AIRBELT K PRODUCT FEATURES

Bag Full or Clog Light & Auto Shut Off – A warning light will illuminate and the machine will automatically shut off, when it senses a full bag, a clog in the airflow pathway, or an excessively dirty microfilter. If the vacuum's airflow pathway becomes restricted due to a full bag or the existence of a clog, the amber "BAG FULL OR CLOG" light (located on top of the canister near the ON/OFF power control knob) will illuminate. If the user ignores this warning, the suction motor will heat up due to the lack of cooling provided by the airflow. Once the motor reaches a certain temperature it will shut off to protect itself from damage. The user should turn the switch off, unplug the machine and immediately insert a new bag or remove the clog (to remove a clog, refer to the Clog Removal section on page 13). After approximately 30 minutes, the motor will have cooled and the vacuum can be restarted. If the airflow is still restricted, the "BAG FULL OR CLOG" light will again illuminate and the machine will shut off. This feature prevents damage to the motor due to overheating.



Shock Absorber Provides Furniture and Wall Protection – The "AIRBELT" bumper that surrounds the K canisters acts as a protective barrier. The soft foam bumper with its durable textile covering protects furniture, walls and the vacuum itself from damage during use.



Personalized Vacuums – AIRBELT canister vacuums can be personalized with a replacement AIRBELT textile available in several patterns and colors.

Large Operating Range – A 37-foot operating range saves time because it minimizes the number of electrical outlets needed during use.

Quick-release Connections – The AIRBELT K models allow for quick and convenient connection of telescopic tubes, power brush heads, accessory cleaning heads and on-board tools.

Comfortable Ergonomic Handle – The AIRBELT handles are ergonomically designed and positioned to reduce wrist and arm fatigue. For extra comfort, an additional swivel is built into the handle-to-hose connection.

Mid-sized Canister Vacuum – The SEBO AIRBELT K3 and K2 are considered mid-size canister vacuums, which means they are machines medium in size that offer mid-sized, on-board attachments and a mid-sized filter bag with a dirt capacity of .8 gallons.

Rubber-coated Wheels and High Quality Castors – The quality of the wheels and castors on SEBO canisters prevent damage to floors and rotate 360° for easy maneuverability.

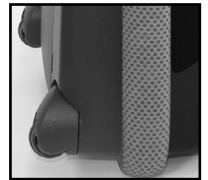

Three On-board Tools – The vacuum comes standard with a crevice nozzle, dusting brush and upholstery nozzle. The dusting brush is mounted on the telescopic tube, and the crevice and upholstery nozzles are on the canister. Many optional accessories are also available.



Dusting Brush Crevice Nozzle
Upholstery Nozzle

AIRBELT K2 TURBO AND AIRBELT K2 KOMBI

SEBO AIRBELT K2: The AIRBELT K2 Turbo, and the AIRBELT K2 Kombi are straight-suction vacuums. As a result, they differ from the AIRBELT K3 Premium in the following two ways:

Variable Suction Control on Canister Body – Because the AIRBELT K2 vacuums do not have an electrified hose and telescopic tube, the variable suction control knob is located on the canister body, not the handle.



Can Not Use a Power Brush – The AIRBELT K2 Turbo and the AIRBELT K2 Kombi do not have an electrified telescopic tube and hose; therefore, they do not accommodate an electrified power brush. Instead, the AIRBELT K2 Turbo comes standard with the Turbo TT-C Head for carpet and a Parquet Brush for hard floors, and the AIRBELT K2 Kombi comes standard with either the Kombi Nozzle (AM models) or the Premium Kombi Nozzle (FC models) for rugs and carpet.



TT-C Turbo Head



Parquet Brush



Kombi Nozzle
AM models



Premium Kombi Nozzle
FC models

AIRBELT K3 PREMIUM

Designed for All Floor Surfaces. AIRBELT K3 Premium:

The AIRBELT K3 Premium has an electrified hose and telescopic tube designed to accommodate the ET-1 power head. The ET-1 is designed to provide thorough brushing for optimal cleaning of carpets.

Both Carpet and Hard Floor Cleaning – With a power brush to clean carpets and a Parquet Brush to clean hard floors, the AIRBELT K3 provides all the flexibility needed to care for a variety of floor surfaces. The Parquet Brush comes standard on AM models and the Premium Parquet Brush comes standard on FC models.

High-quality Telescopic Tube and Hose – On the K3, the power cord is built inside the telescopic tube and suction hose. This eliminates unsightly external wires and enables unobstructed and convenient handle height adjustment.

Suction Adjustment Slider – The vacuum's suction power can be adjusted from 0 to 1,250 watts by a slider switch conveniently located on the handle.

Brush Roller Switch on Handle – To switch from brushing action to straight suction for delicate floors, press the brush roller power switch on the handle. This will power off the brush roller on the power head. All indicator lights on the power head will turn off until the brush roller button is switched on again.



Parquet Brush
AM models



Premium Parquet Brush
FC models



Powerful Vacuum Motors Provide Excellent Cleaning – The canister suction motor is 1,250 watts, and the power head motor is 175 watts (ET-1), for a total of 1,425 watts.

The SEBO ET-1 (12" wide, 10 1/2" cleaning width) – This power head delivers cleaning flexibility because its brush action aggressively cleans carpeting, but the brush roller may be switched off on the handle so delicate rugs and hard floors can be cleaned with straight suction. Its amazing 180° steering ability provides maneuverability around furniture, and the extension side of the L-shaped head makes cleaning edges and under counters easy.

Brush Obstruction Light & Auto Shut Off – If an obstruction becomes jammed in the brush roller, a red brush-warning light will quickly flash, the brush roller will immediately stop spinning and the vacuum will shut off. The user should turn the power switch off, unplug the machine, and immediately remove the obstruction. If the user restarts the machine without removing the obstruction, the power head will again shut off and the red light will flash. This prevents the belt from breaking and protects the motor and carpet from damage.



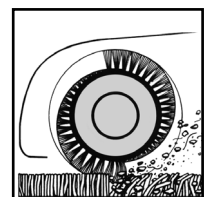





































Incorrect Height Setting or Brush Deterioration Light – To ensure optimum cleaning at all times, a red brush-warning light will illuminate, to indicate when the brush height is set too high for effective cleaning or when the brush roller should be replaced due to excessive wear.



OPTIONAL ATTACHMENTS, ACCESSORIES, BAGS & FILTERS

In addition to the standard on-board tools, a variety of optional attachments are available. The 9' 2" extension hose (extends suction hoses) and the 22" extension wand are very popular because they create useful tools for cleaning stairs and out-of-reach areas. Another popular attachment is the hand-held turbo brush for removing pet hair from upholstery.

SEBO filter bags can be purchased in boxes of eight and filters are sold separately. Also, bags and filters can be purchased together in model-specific kits called "Service Boxes." SEBO bags, filters and accessories are reasonably priced and widely available. To create a fresh scent while vacuuming, "SEBO FRESH" is available. To use, deposit a scented stick in the filter bag.

ATTACHMENTS								
Included All K3 Premium Models	 ET-1 Power Head Red, Black or White	 Dusting Brush with Horsehair Bristles #1387GS	 Upholstery Nozzle #6627GS	Included K3 Premium AM Models	 Parquet Brush #6391DA	Included K3 Premium FC Models	 Premium Parquet Brush #7200GS	
	 Crevice Nozzle #1092GS							
Included All K2 Models	 Dusting Brush with Horsehair Bristles #1387GS	 Upholstery Nozzle #6627GS	Included K2 Turbo Models	 TT-C Turbo Head #8365GS	Included K2 Kombi AM Models	 Kombi Nozzle #8351GS	Included K2 Kombi FC Models	 Premium Kombi Nozzle #7260GS
	 Crevice Nozzle #1092GS			 Parquet Brush #6391DA				
Optional Attachments	 24" Crevice Nozzle #1093JV	 9' 2" Extension Hose #1495AM	 Radiator Brush #1496GS	 Hand-held Turbo Brush #6179ER	 Flat Upholstery Nozzle #1090HG	 Wall & Floor Brush #1325GS	 Turn and Clean Parquet Brush #1327WS	
	 Dusting Brush Nylon Bristles #1329GS	 Dusting Brush Large Opening Nylon Bristle #1094GS	 Premium Parquet Brush #7200GS	 Parquet Brush #6391DA	 TT-C Turbo Head #8365GS	 Premium Kombi Nozzle #7260GS	 Kombi Nozzle #6735GS	 Kombi Nozzle #8351GS
BAGS, FILTERS, ACCESSORIES AND WEAR ITEMS								
 8 AeraPure™ Bags* #6629AM	 Pre-motor, S-class Microfilter* #6191AM	 Exhaust Filter* #6608ER	*All three items are also available as a Service Box containing 8 Bags, an Exhaust Filter and a Pre-motor, S-class Microfilter.		 Service Box #6695AM	 HEPA Service Box #6431AM	HEPA Service Box contains 8 Bags, an Exhaust Filter, and a HEPA Pre-motor Microfilter.	
 Filter Set includes a Pre-motor S-class Microfilter and an Exhaust Filter #6696AM	 AIRBELT Cover Gray Black, Solid #6047AM01	 AIRBELT Cover Silver/Black, Ovals #6047AM07	 AIRBELT Cover Orange/Silver, Squares #6047AM12	 12" Brush Roller #5010AM	 12" Brush Roller (Soft Bristle) #5010GE	 SEBO FRESH 1 Pkg. of 5 #0496AM		

NOTE: The **Premium Parquet Brush** and the **Premium Kombi Nozzle** have brush strips that are removable for cleaning and replacement.

To change the brush strip, remove the yellow cap with a screwdriver and pull out the brush strip. After inserting the new brush strip, the cap has to click into place again.

STANDARD FEATURES OF ALL SEBO VACUUMS

SEBO'S FILTRATION SYSTEM:

Bagged vs. Bagless . . . Bags are Better! – Top-fill, three-layer AeraPure™ Bags are an integral part of SEBO's filtration system because they hold virtually all the dirt captured by the vacuum, which improves the effectiveness and useful life of the microfilters. They also ensure continuously strong suction because dirt enters from the top, deposits at the bottom, accumulates upward, and air exits through the sides, which allows unimpeded airflow as they fill to capacity. And they can be tightly sealed with a hygiene cap when full, so no dust can escape into the air during bag removal and disposal.

In contrast, without bags to hold nearly all the captured dirt, the microfilters on bagless vacuums quickly clog from excessive dirt build-up and must be replaced often, or a loss of suction and cleaning effectiveness will occur. In addition, dust and other allergens become airborne when emptying bagless dirt containers. Lastly, bagless vacuum microfilters are expensive, usually costing more than a multi-year supply of SEBO filter bags.

S-class, Pre-motor and/or Exhaust Microfilters

– S-class, Pre-motor and Exhaust Microfilters (S = "Schwebstoff" = airborne particles) are made from electrostatically charged, micro-fiber material, which attracts and captures dust particles from the airflow of the vacuum before and after it passes over the motor to cool it. Cooling the motor with super-clean air increases motor life and reduces the possibility of maintenance, even after many years of use. Also, the exhaust air is cleaned to the highest level before being emitted from the machine. The S-class Standard requires filters to absorb greater than 99.9% of particles down to 0.3 microns in diameter. For comparison, 100 microns is the diameter of a human hair. Their advantages are a relatively open texture that allows smoother airflow for better suction performance, a longer life expectancy, and they cost less than HEPA filters.

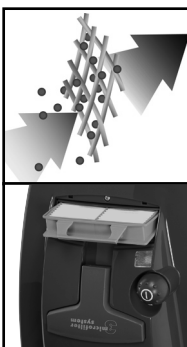

HEPA, Pre-motor and/or Exhaust Microfilters (Optional)

– HEPA Microfilters ("High Efficiency Particulate Air") remove a minimum of 99.97% of all airborne particulate matter down to 0.3 microns in diameter. Because these filters use small, grid-like structures to capture dust particles, dirt build-up clogs the airflow pathway sooner than what is expected from S-class microfilters. However, SEBO's HEPA microfilters are sold along with three-layer AeraPure™ bags, which provide highly effective filtration before the airflow goes through the HEPA microfilter, greatly increasing life expectancy and reducing the potential of diminished air flow.



Designed and Manufactured in Germany – Legendary quality, reliability and performance make SEBO vacuums the first choice of cleaning professionals throughout the world.

World's Best Pet Vacuums – Because of superior power-head and brush-roller technology, SEBO vacuums are the world's best for pet hair removal!

Tightly Sealed Vacuums Ensure Effective Filtration – Dirty air, which flows through a vacuum, can only be filtered completely if it does not escape into the room through seams or seals in the machine. This is why all SEBO vacuums have tight seals throughout.

Many vacuum companies with high-filtration claims are actually quoting specifications made by the manufacturer of the filter material, as measured in the laboratory, not the filtration effectiveness of the vacuum itself while operating. Whether or not dirty air can escape through leaks in the body of the machine is not considered. The filtration effectiveness of SEBO vacuums is tested while they operate.

Reliable, Commercial-grade Components – All SEBO vacuums are constructed with thick, reinforced, ABS plastic, aluminum and metal parts, steel axles and bearings, and high-end, quality motors. Therefore, SEBO users own reliable, long-lasting vacuum cleaners. Competing vacuums are made with thin, flimsy, inexpensive, plastic materials, none of which are reinforced, and typically have useful lifespans of one or two years.

Rubber Wheels and Soft Bumpers Protect Homes – Smooth-gliding, rubber wheels protect hard floors and provide exceptional maneuverability. In addition, the bumpers that surround the power heads and the soft AIRBELT bumpers that surround SEBO's canisters protect furniture, walls, and vacuum housings from incurring scuffs and scratches during use.

Advanced, Brush-roller Technology – SEBO's brush rollers are uniquely designed to funnel hair and debris into the power head's airflow channel, which improves vacuum cleaning performance on all flooring surfaces.

Changing Bags is Easy and Clean – SEBO filter bags can be changed in just a few seconds, and a hygiene cap keeps dust sealed inside during removal and disposal.

Save Money! SEBO Vacuums Last for Years and Extend Carpet Life!

– If properly maintained, SEBO vacuums save ordinary, residential users hundreds of dollars, by providing excellent performance for ten to fifteen years or more, and their deep-cleaning, power-brush technology extends the life of carpets. Typical vacuums perform poorly, even when new, and usually do not last beyond two years. So six or seven "disposable vacuums" must be purchased during the average life expectancy of just one SEBO machine.

Incredible Warranty Coverage – All SEBO models include a FREE seven-year warranty on the motor and five-years on non-wear parts and labor charges.

IDENTIFICATION OF PARTS

- | | |
|---|------------------------------------|
| 1. Handle grip | 13. Hose |
| 2a. Suction-control slider (K3 Premium) | 14. Exhaust filter cover |
| 2b. Brush roller switch (K3 Premium) | 15. AIRBELT bumper & textile cover |
| 3. Handle release button | 16. Carrying handle |
| 4. Slide button | 17. Suction opening |
| 5. Telescopic tube | 18. Hose release button (K3 only) |
| 6. Power cord | 19. Hose neck |
| 7. Tool release button | 20. Crevice nozzle |
| 8. Kombi Nozzle | 21. Parking attachment holder |
| 9. On/Off power knob (K3 Premium) | 22. Power cord shroud |
| 10. Warning light | 23. AIRBELT clip |
| 11. Upholstery nozzle | 24. Parking attachment holder |
| | 25. Filter bag cover release catch |
| | 26. Filter bag cover |

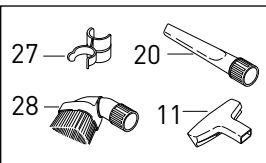
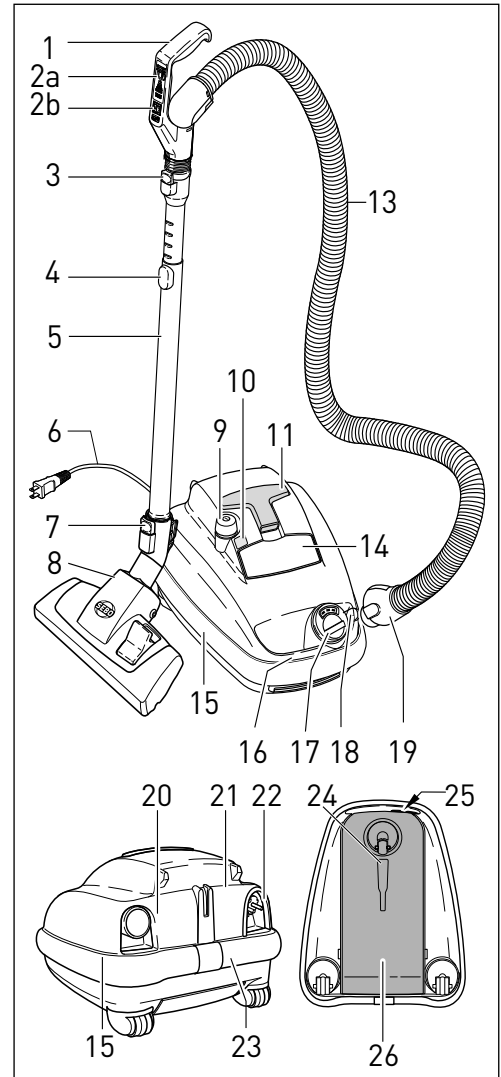

Standard Attachments

- | | |
|-----------------------|------------------------|
| 20. Crevice nozzle | 27. Dusting brush clip |
| 11. Upholstery nozzle | 28. Dusting brush |

Brushes and Heads

- | |
|---|
| 8. Kombi Nozzle - standard for K2 Kombi AM models - Part #8351GS |
| 29. Parquet Brush - standard for K3 Premium AM models, standard for K2 Turbo - Part #6391DA |
| 30. ET-1 Power Head - standard for K3 Premium
Part #9260AM Arctic White
Part #9261AM Black (Onyx)
Part #9296AM Red |
| 31. Premium Kombi Nozzle - standard for the K2 Kombi FC models - Part #7260GS |
| 32. Premium Parquet Brush - standard for K3 Premium FC models - Part #7200GS |
| 33. TT-C Turbo Head - standard for the K2 Turbo - Part #8365GS |

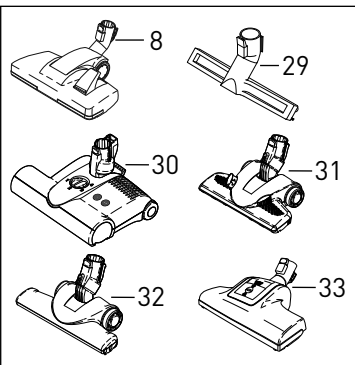

ASSEMBLY

Push the neck (19) of the hose (13) into the suction opening of the canister (17). **K3:** The notch in the suction opening will line up with the raised bar on the neck. When the notches are lined up correctly, the neck will snap firmly into place. To release the hose from the suction opening, press the release tab (18) on the neck of the hose (19), and pull the neck out. **K2:** To release the hose from the suction opening, squeeze the tabs (37) on the retaining ring and pull the neck out.

Connect the handle (1) to the top of the telescopic tube (5). Snap in place. To release the telescopic tube from the handle, push the handle release button (3) and slide the handle out.

Attach the head or brush to the bottom of the telescopic tube (5). Insert the bottom of the telescopic tube into the neck of the head or brush (38) until it locks into place; or line up the square hole in the telescopic tube with the notches in the front of the neck, and snap firmly into place. To release a head or brush from the telescopic tube (5), push the release button (7), and pull the head or brush tool off the end of the telescopic tool. The release button (7) is in the same position on all of the heads, brushes and power heads.

To attach the dusting brush clip (27), locate the two raised ridges on the upper end of the telescopic tube (5) just below the handle. Push the clip onto the tube directly below the ridges then slide the clip up until it locks onto the ridges. Snap the dusting brush (28) into the holder.

NOTE: To attach the ET-1 power head to your K3 Premium, please refer to your power head owner's manual for instructions. Attaching incorrectly could cause damage.

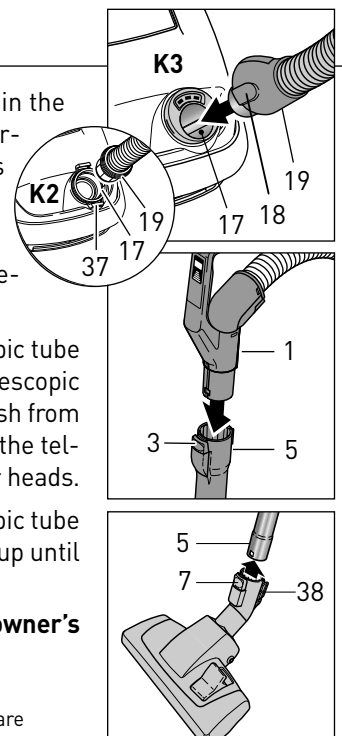

NOTE: All illustrations shown in this manual represent the K3 model except where part numbers and instructions are different for each model.

OPERATING INSTRUCTIONS

Starting The Machine

Your AIRBELT K canister is equipped with a soft start system and variable suction controls. To help you better understand the various power control options on your SEBO canister, please follow the instructions below.

K3 Premium Users - Figures 1, 2, 3 & 4

Before turning on your canister, make sure that the vacuum handle is in its upright locked position.

1. With the canister main power knob (9) in the OFF position, and the suction-control slider on the handle (#2a, figure 4) in the OFF position, pull the power cord out from the base of the canister (figure 1). The power cord should be unwound from the cable reel at least two thirds of its length.
Note: do not over-extend the cord.
2. Plug the polarized power cord into a 120 volt wall outlet located near the floor.
3. Press the main power knob (9) on the base of the canister gently with your foot or hand. The green light (10) will illuminate indicating that the power is on..
4. Slide the suction-control slider (#2a, figure 4) toward the MAX position. It will move freely between 0 suction and MAX suction. Set the slider to the suction desired.
5. When the power head is on with the handle in the upright locked position, the brush roller will not spin. To release the ET-1 power head from the upright locked position, press down on the foot pedal, (#41, figure 3), lower the handle into the normal operating position and push the brush roller switch on the handle (#2b, figure 4) to engage the brush roller. The green light on the power head will illuminate. The handle can be lowered to a horizontal position useful for vacuuming under beds.

Note: K3 users - see the ET-1 Owner's Manual for power head instructions.

K2 Turbo and K2 Kombi Users - Figures 1 & 2

Before turning on your canister, make sure that the vacuum handle is in its upright locked position.

1. With the canister main power knob (9) in the OFF position, pull the power cord out from the base of the canister (figure 1). The power cord should be unwound from the cable reel at least two-thirds of its length. **Note:** do not over-extend the cord.
2. Plug the polarized power cord into a 120 volt wall outlet located near the floor.
3. Press the main power knob (9) on the base of the canister gently with your foot or hand.

Suction Control

K3 Premium Users - Figure 4

You may adjust the suction with the suction-control slider (2a) as you vacuum different surfaces or when using the accessory tools. For optimal cleaning and brushing, operate the machine at the maximum suction power setting and push the power head slowly over the carpet.

When the canister's main power knob (9) is in the ON position, you may turn the suction and the power head off and on with the suction-control slider (2a). To turn the power off using the suction-control slider, pull the slider to 0 suction, then continue pulling the slider up until it "clicks" into the OFF position. The green power head light will then shut off (the green light on the canister (#10, figure 2) will remain illuminated until the vacuum is powered off using the main power knob).

K2 Turbo and K2 Kombi Users - Figure 5

The on/off and suction-control knob is located on the top side of the canister (9). Rotate the knob counter-clockwise for maximum suction. Rotate clockwise to reduce suction for vacuuming curtains or delicate fabrics.

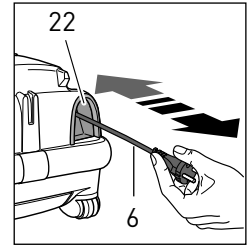

Figure 1

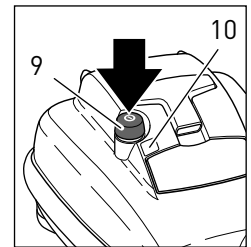

Figure 2

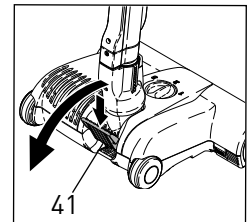

Figure 3 - K3

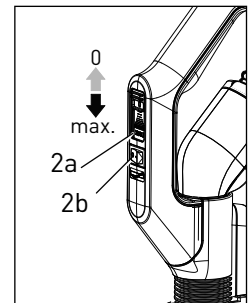

Figure 4 - K3

0 = Zero Suction
MAX = Maximum Suction
ON position - Move the slider toward MAX.

OFF position - Pull the slider up to 0 suction then continue pulling the slider up until it "clicks" into the OFF position.

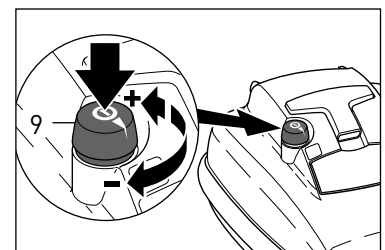

Figure 5 - K2

Brush Roller Switch - K3 Premium - Figure 6

To switch from brushing action to straight suction for delicate floors, press the brush roller power switch (2b) on the handle. This will power off the brush roller on the power head. All indicator lights on the power head will turn off until the brush roller button is switched on again.

Adjusting the Telescopic Tube - Figure 7

Adjust the telescopic tube (5) to the correct height by pushing the slide button (4) and gently pulling the tube out to lengthen, or pushing it in to shorten. Release the slide button (4) to lock the tube to the adjusted height.

Using the Telescopic Tube, Hose & Attachments - Figures 8 & 9

ALWAYS TURN OFF THE CANISTER AND UNPLUG BEFORE CONNECTING OR DISCONNECTING THE HOSE (13), TELESCOPIC TUBE (5) OR POWER HEAD.

The telescopic tube (5) is useful for vacuuming corners and hard-to-reach areas. You may use the telescopic tube without a brush, power head or attachment. To remove a brush or power head, switch off the power knob (9) and unplug the vacuum. Then, press the tool release button (7) and pull the tube out. The crevice nozzle (20) and dusting brush (28) may be inserted onto the end of the tube. To use the upholstery nozzle (11), fit it onto the end of the crevice nozzle (20). It is not necessary to turn off the vacuum while switching the **standard** attachments (the crevice nozzle, upholstery nozzle or dusting brush). After use, switch off the power, unplug the vacuum and remove attachment. Re-insert the telescopic tube into the power head or brush, turning the tube if needed, until you hear it click into place.

To use the hose without the telescopic tube, switch off the power and unplug the vacuum. Push the handle release button (3) and pull the HANDLE out of the end of the telescopic tube. Do not try to separate the hose from the handle! Insert the crevice nozzle (20) or dusting brush (28) onto the end of the handle. To use the upholstery nozzle (11), fit it onto the end of the crevice nozzle (20). After use, switch off the power, unplug the vacuum and remove the attachment. Re-insert the handle into the telescopic tube making sure it is seated correctly and snap it into place.

Bag Full or Clog Indicator & Auto Shut-Off - Figure 10

When the "BAG FULL OR CLOG" indicator, located on top of the canister (10), illuminates, airflow is reduced due to a full bag, a clog in the airflow pathway, or an excessively dirty filter. Turn the power off, unplug the machine and immediately insert a new bag (see page 12) or remove the clog (see page 13).

If the user ignores the warning indicator, the motor will shut off to protect itself from damage. The user should turn the power off, unplug the machine and immediately insert a new bag or remove the clog. If the airflow is still restricted, the "BAG FULL OR CLOG" indicator will illuminate again and the machine will shut off.

Vacuuming fine dust may require an earlier filter bag change even though the filter bag is not full. Fluff may overfill the bag without the light coming on.

The bag full indicator works more efficiently at full power. Check the bag full status regularly at full suction power.

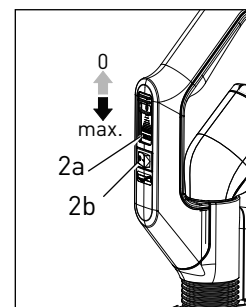

Figure 6 - K3

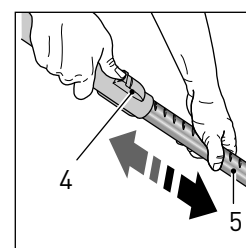

Figure 7

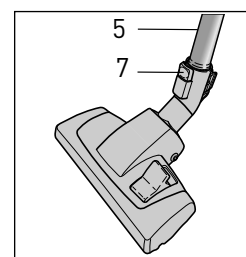

Figure 8

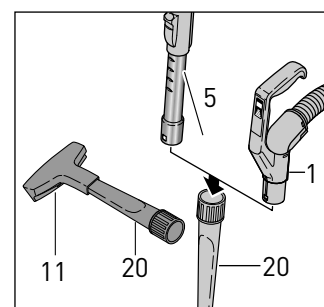

Figure 9

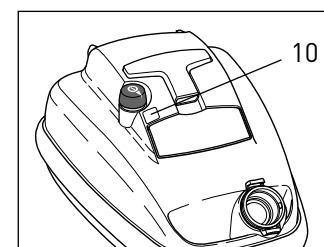

Figure 10



WARNING!

The quality, condition, coating, texture, age and manufacturing technique of all floor surfaces vary. Therefore, vacuums with rotating brushes, including your SEBO, may damage some floor coverings or surfaces. Some types of high-gloss hardwood floors, cushion vinyl, berber carpets, long shag, and delicate or hand-woven carpets are particularly vulnerable to damage by rotating brushes. When possible, consult the materials supplied by your flooring manufacturer for information on proper upkeep and cleaning. **To ensure that your new SEBO vacuum cleaner is compatible with your floor, please test the vacuum cleaner on each type of flooring surface in a small inconspicuous area to determine if any damage occurs. If damage occurs, stop using the vacuum cleaner immediately!**

Retracting the Cord - Figure 11

To retract the cord, switch the vacuum off, unplug it from the outlet, then gently tug the cord. The mechanism will automatically rewind the cord. Hold plug while rewinding into the cord wheel. Do not allow the plug to whip while rewinding. The rewind mechanism will stop automatically. Before rewinding the cable, always switch off and unplug the vacuum.

ALWAYS TURN THE POWER OFF ON THE CANISTER BEFORE UNPLUGGING THE UNIT.

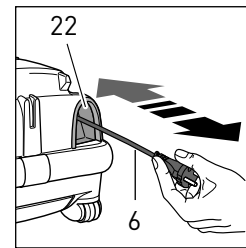

Figure 11

Storing the Vacuum- Figure 12

The vacuum can be stored with the canister in a horizontal or vertical position. The Parquet Brushes, Kombi Nozzles and TT-C Turbo Head have a parking tab located on the neck (39). Insert the parking tab into the upper side of the parking groove and slide down firmly. For vertical storage, or for easy carrying, use the parking slot on the underside (24). For horizontal storage, use the parking slot on the end of the canister (21).

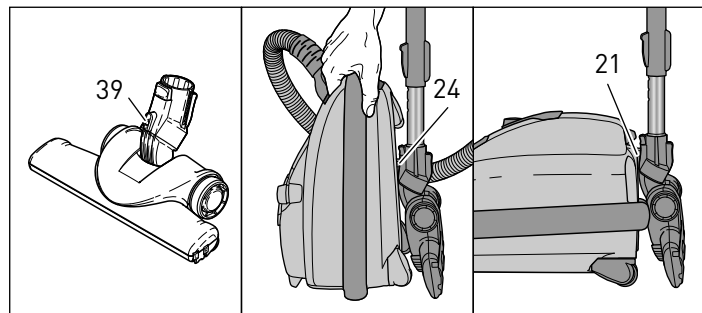

Figure 12

USE AND MAINTENANCE OF BRUSHES AND HEADS

⚠ Always unplug vacuum from outlet before dismantling any part of machine! To remove a brush or power head, switch off the power and unplug the vacuum. Then, press the tool release button (7) and pull the tube out.

NOTE! K3 Premium users with the ET-1 power head, please refer to your power head user's manual for more detailed instructions for operating and maintaining your power head.

Parquet Brush - Figure 13

The Parquet Brush (29) was designed specifically for vacuuming hard floors. It is lightweight with soft bristles, so it glides gently over floors and provides easy maneuverability. Fibers and hair can be pulled out of the bristles manually, or vacuum the bristles with the telescopic tube.

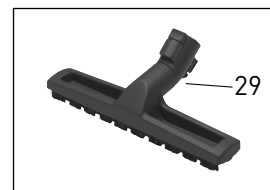

Figure 13

Premium Parquet Brush - Figure 14

The Premium Parquet Brush (32) is especially designed for use on hard surfaces. The brush should be cleaned regularly. Remove the parquet brush from the telescopic tube to clean. Fibers and hair can be pulled out of the bristles manually, or vacuum the bristles with the telescopic tube. The brush strips are removable for cleaning and replacement.



Figure 14

TT-C Turbo Head - Figure 15

The TT-C Turbo Head (33) has an air-driven rotating brush for gentle brushing of carpets. The Turbo Head can be adjusted for high and low pile carpet. To adjust the head for high pile carpet, push the slider button (43) upward. For low pile carpet, push the slider button (43) downward. The rotating brush should be cleaned regularly. Remove the Turbo Head from the telescopic tube to clean. Remove fibers and hair from the brush manually.

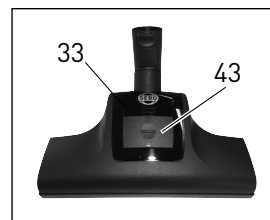

Figure 15

Kombi Nozzle and Premium Kombi Nozzle - Figure 16

The Kombi Nozzle (8) and the Premium Kombi Nozzle (31) are adjustable for carpet or hard floors. Use the toggle button (44) on either nozzle to raise the brush for carpet or lower the brush for hard floors. The brush should be cleaned regularly. Remove the nozzle from the telescopic tube to clean. Fibers and hair can be pulled out of the bristles manually, or vacuum the bristles with the telescopic tube.

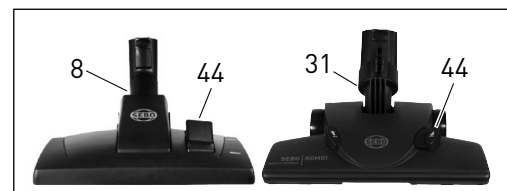

Figure 16

NOTE: The Premium Parquet Brush and the Premium Kombi Nozzle have brush strips that are removable for cleaning and replacement. To change the brush strip, remove the yellow cap with a screwdriver and pull out the brush strip. After inserting the new brush strip, the cap has to click into place again.

VACUUM MAINTENANCE



Always unplug vacuum from outlet before dismantling any part of machine!

Changing the Filter Bag - Figure 17

To change the filter bag (45), set the canister upright (as shown in figure 17), press the cover release catch (25) and lower the filter bag cover (26). Grasp the green filter bag sealing plate (46), slide the plate from the holder (48) and push the filter bag cap (47) on to seal the bag. Slide the sealing plate (46) of a new bag into the bag holder slots (48) and push it in firmly until it locks into place. Close the cover, making sure it snaps shut completely. You may find it convenient to store the bag cap inside the filter bag housing below the filter bag. Do not re-use the filter bags. Note: the nature of the contents of the filter bag will affect the point at which it needs changing. Fine dust may require an earlier change even though the bag is not full. Fluff or hair allows air to pass through easily, so the filter bag may overflow before the amber "bag full" light illuminates.

The "bag full or clog" light works correctly only at full power. At lower power levels, the "bag full or clog" light may illuminate incorrectly. Check the status of the filter bag regularly at full power.

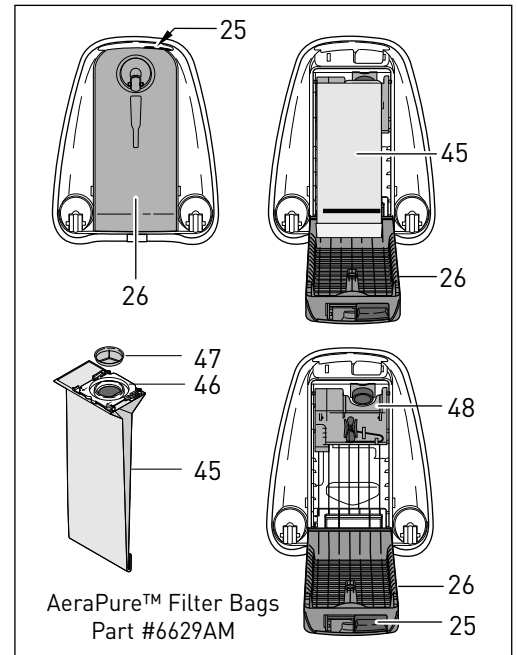

Figure 17

Changing the Exhaust Filter - Figure 18

The exhaust filter (51) needs to be changed when it becomes extremely dirty or clogged with dust, or after approximately 10 to 20 filter bags have been used. To change the exhaust filter, set the canister flat on the floor as shown in figure 18. Remove the printed cover on top of the machine (14) by lifting the catch (49) in the upholstery nozzle recess (see inset, figure 18). Pull out the filter using the handle (50) and fit the new filter into the same position. The filter handle should point toward the upholstery nozzle when it is folded down. Fit the tabs on the bottom of the cover (14) into the grooves and snap the cover down firmly.

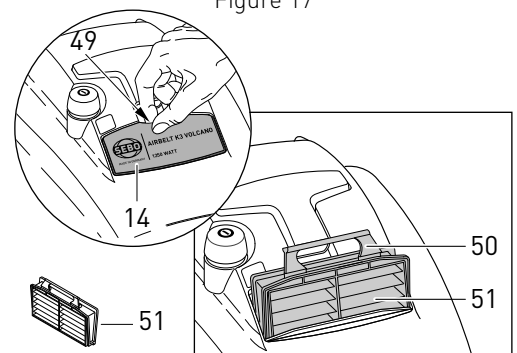

Figure 18

Changing the Pre-motor Microfilter - Figures 17 & 19

After 10 to 20 bags have been used, change the pre-motor microfilter (52). To remove the microfilter, set the canister upright (as shown in figure 17). Press the cover release catch (25) and lower the filter bag cover (26). Remove the filter bag, then remove the cover by sliding it up and out of the grooves (53). Pull the old filter out (52) and slide the new filter into the same position. Replace the filter bag, then re-insert the cover by fitting the tabs into the grooves (53) on both sides and sliding it in and down. Push the cover closed, making sure it snaps shut completely.

K Service Box - 8 AeraPure™ Filter Bags, Exhaust Filter and a Pre-motor Microfilter Part #6695AM

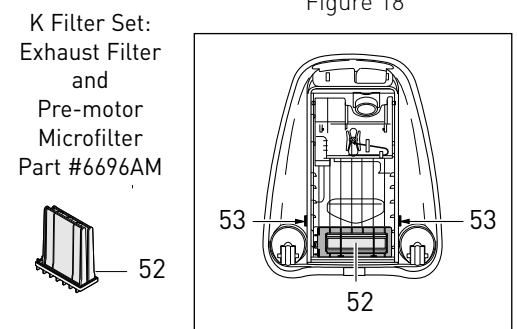

Figure 19

Changing the AIRBELT Textile - Figure 20

If damage occurs to the AIRBELT textile, it will need to be replaced. To remove the textile (15), pry off the clip (55) by inserting the tip of a slot-head screwdriver under the bottom side of the clip. Push downward on the screwdriver until the clip pops off. Grasp the end of the AIRBELT textile and pull - the textile will peel off. The foam bumper (54) remains on the vacuum. To replace the textile, insert the side ribs of the textile into the grooves (56). Start at the back, insert rib into one groove (56), and while holding it down, stretch the AIRBELT textile around the foam (54) into the opposite groove (56). Continue around the vacuum. Secure the ends with the clip (55).

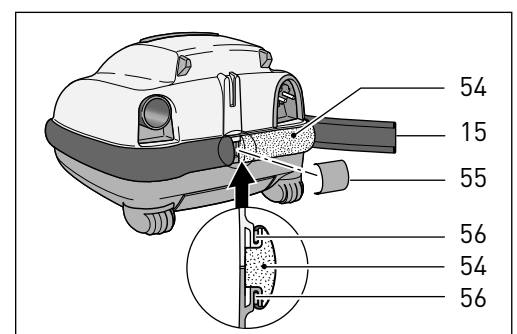

Figure 20

AIRBELT Textile
Part #6047AM/01, #6047AM/07, #6047AM/12

Note: Never operate the vacuum with incorrectly attached filters or without filters, bag, AIRBELT textile or filter bag housing cover (26). Do not re-use filter bags. Do not wash and re-use filters.

CLOG REMOVAL



Always unplug vacuum from outlet before removing any clogs!

NOTE! K3 Premium users with ET-1 power heads, please refer to your power head user's manual for more detailed instructions for removing clogs in your power head.

If the "bag full or clog" warning light (10) remains illuminated after the filter bag has been changed and the filters are in good condition, there is likely a clog in the system.

Clogs in the Head or Brush - Figure 21

Clogs in the swivel neck (57) of a head or brush can be cleared by first pressing the tool release button (7) and removing the brush or head. Check inside the swivel neck channel and clean out pathway.

Clogs in the Telescopic Tube - Figure 21

Remove head from telescopic tube (5) by pushing the tool release button (7) and pulling the tube out. Remove the hose from the top of the telescopic tube by pushing the handle release button (3). A stiff wire or stick can be used to push the clog out of the tube.

Clogs in the Hose - Figures 22, 23 & 24

Check for suction at the end of the hose (19). If you feel reduced suction, the blockage is in the hose. To clear blockages in the hose (13), remove the telescopic tube (5) by pushing the tool release button (7) and pulling the tube out. Hold the hose upright with one hand blocking the top and switch on the machine. If necessary, quickly lift your hand on and off the end of the hose. If that does not clear the clog, you may also clear clogs by reversing the hose. **K3 Premium:** After removing the telescopic tube, push the release button (18) on the hose neck (6) and remove the hose from the machine.

K2 Turbo and K2 Kombi: After removing the telescopic tube, squeeze the tabs (37) on the retaining ring and pull the hose neck out.

Remove the hose handle (1) from the telescopic tube by pressing the handle release button (2). Insert the handle end of the hose (1) into the suction opening (17). Hold the hose upright with one hand blocking the top and switch on the machine. If necessary, quickly lift your hand on and off the end of the hose.

Note: Do not insert a wire or stick into the hose. Doing so may cause damage to the hose.

Clogs in Entrance to Filter Bag - Figure 25

Remove hose (10) from vacuum cleaner (see figure 22), open the filter bag cover and remove the filter bag. (figure 17, page 12). Clean out entrance to bag (58).

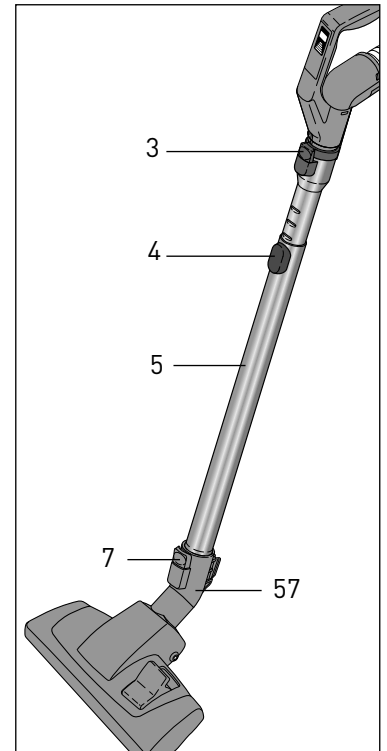
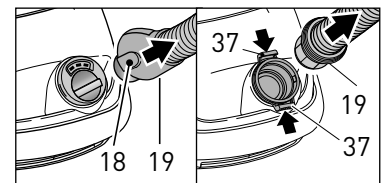

Figure 21



K3

Figure 22

K2

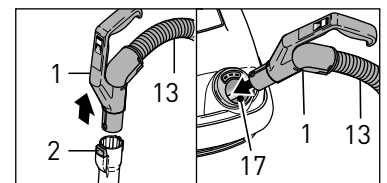

Figure 23

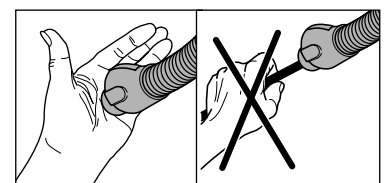

Figure 24

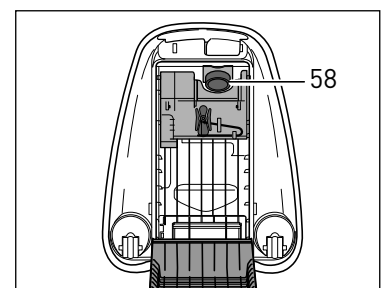

Figure 25

TROUBLE-SHOOTING GUIDE



Always unplug vacuum from outlet before dismantling any part of the machine!

PROBLEM	REASON	SOLUTION
Does not turn on	1. Telescopic tube not inserted properly.	1. See page 8.
	2. Not plugged into working outlet.	2. Use another outlet.
	3. Cable worn.	3. Replace cable.
	4. K3: The suction-control slider switch is set to "0" ("off" position).	4. K3: Set slider switch to "on" position. See page 10.
Bag full or clog light on Bag full or clog light on & machine shuts off	1. Bag full.	1. Replace filter bag. See page 12.
	2. Clog in hose, telescopic tube, brush or head, or entrance to filter bag.	2. See Clog Removal on page 13. K3 users with clog in power head attachment: refer to clog removal in the ET-1 owner's manual.
	3. Pre-motor microfilter is dirty.	3. Replace pre-motor microfilter. See page 12.
	4. Exhaust filter dirty.	4. Replace exhaust filter. See page 12.
Does not pick up	1. Hose/handle assembly not correctly inserted.	1. Re-insert hose/handle assembly making sure that it is lined up properly and is snapped into place. See page 8.
	2. The suction control dial is rotated to no suction setting	2. K2: Rotate suction control dial to yellow setting. See page 9.
	3. Filter bag cover not closed.	3. See below.
Filter bag door won't fully close	1. Filter bag cover not fully closed.	1. Re-insert bag. Lock the cover down firmly.
	2. Bag not inserted properly	2. Re-insert bag. Lock the cover down firmly.
	3. Pre-motor microfilter not properly inserted.	3. Remove the filter bag cover (26) and make sure the pre-motor microfilter housing is seated firmly in place (see pg. 12, figure 19).

NOTE: E3 Premium users, please see the ET-1 Power Head Owner's Manual for additional trouble shooting guide information.

AIRBELT K2 TURBO AND K2 KOMBI SCHEMATIC AND PARTS LIST

- #9678AM AIRBELT K2 Turbo - Black Cherry (USA)
- #9678FC AIRBELT K2 Turbo - Volcano (Canada)
- #9695FC AIRBELT K2 Turbo - Onyx (Black) (Canada)
- #9679AM AIRBELT K2 Kombi - Midnight Blue (USA)
- #9679FC AIRBELT K2 Kombi - Midnight Blue (Canada)
- #9677FC AIRBELT K2 Kombi - White (Canada)

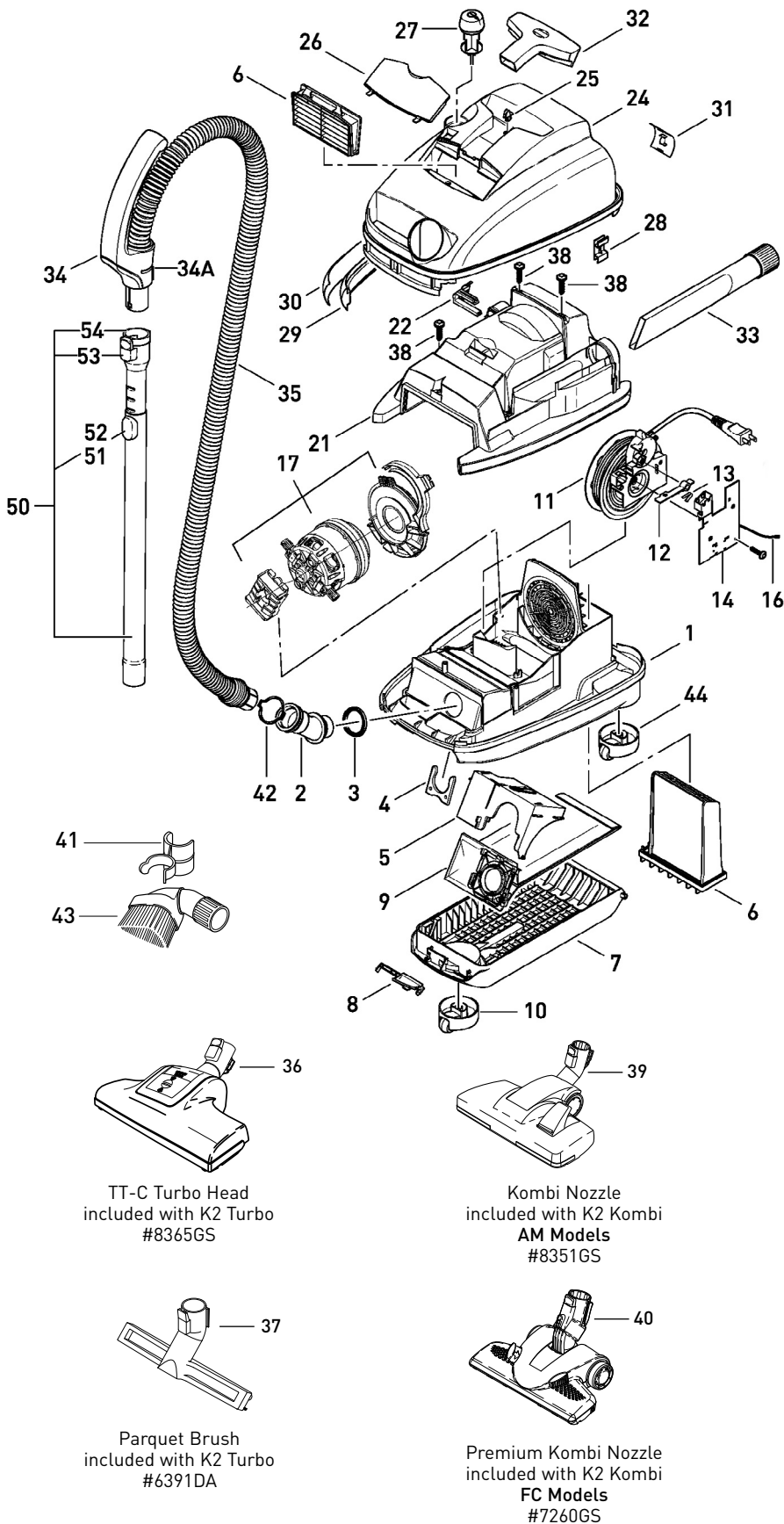

Canister with Handle/Hose

#9678AM K2 Turbo Black Cherry (dark red/gray black) #9678FC K2 Turbo Volcano (dark red/gray black)

Pos.	Part #	Description
1	6754GS	Bottom casing w/castors (44)
2	6675GS	Suction neck
3	6014	Seal
4	6042WS	Spring lock
5	6681HG	Bag holder, complete
6	6696AM	Pre-motor microfilter & exhaust filter set
7	6756GS	Bag cover w/castor (10)
8	6607GS	Cover release
9	6629AM	AeraPure™ filter bag
10	6752GS	Caster for bag cover
11	665603E	Cord reel w/lever & leaf spring (12&13)
12	6621	Switch lever w/leaf spring (13)
13	1739	Leaf spring
14	6641ER	Electronic controller K2 w/switch
16	6638	Internal cable, white
17	6631ER	Vac motor 1250W includes motor mount, adaptor, internal cable w/thermal cut-off (pos. 15)
21	6679GS	Motor cover
22	6622GS	Plug surround
24	6680SR1	Top casing (25)
25	6625ER	Release clip w/screw
26	6403SRER	Exhaust filter cover, dark red
27	60666VO	On/off knob, orange
28	6086HG	Casing clip
29	6623UL	Foam bumper - K Series
30	6047AM12	AIRBELT textile, orange/silver, squares (incl. pos. 31)
31	6048GS	AIRBELT clip
32	6627GS	Upholstery nozzle
33	1092GS	Crevice nozzle
34	6300GS	Handle grip K2, cpl. (incl. pos. 34A)
34A	6303GS	Retaining ring
35	6447GS	7' hose w/couplings & handle K2 (34&34A)
36	8365GS	TT-C Turbo Head
37	6391DA	Parquet Brush
38	0105	Screw 3.9 x 19
41	6694GS	Clip for dusting brush
42	6612GS	Retaining ring
43	1387GS	Dusting brush
44	6751GS	Castor for bottom casing
50	6237ER	Telescopic tube stainless steel, cpl. (incl. pos. 51-54)
51	6425ER	Sliding knob
52	6238ER	Locking mechanism
53	6480ER	Release button cpl.
54	1736GS	Fitting neck

#9695FC K2 Turbo Onyx (black) Machine Exceptions

24	6680SW	Top casing, black (25)
26	6403SWER	Exhaust filter cover, black
27	60613WE	On/off knob, white
30	6047AM07	AIRBELT textile, silver/black, ovals (incl. pos. 31)

#9679AM K2 Kombi, #9679FC K2 Kombi Midnight Blue Machine Exceptions

24	6680DB1	Top Casing, midnight blue (25)
26	6405DBER	Exhaust filter cover, midnight blue
27	60613WE	On/off knob, white
30	6047AM01	AIRBELT textile, gray black, solid (incl. pos. 31)
39	8351GS	AM models: Kombi Nozzle
40	7260GS	FC models: Premium Kombi Nozzle

#9677FC K2 Kombi White Machine Exceptions

24	6680WE	Top casing, white (25)
26	6403WEER	Exhaust filter cover, white
27	60613WE	On/off knob, white
30	6047AM01	AIRBELT textile, gray black, solid (incl. pos. 31)
40	7260GS	Premium Kombi Nozzle

AIRBELT K3 PREMIUM SCHEMATIC AND PARTS LIST

- #90687AM AIRBELT K3 Premium - Red (USA)
- #90687FC AIRBELT K3 Premium - Red (Canada)
- #90688AM AIRBELT K3 Premium - Onyx (Black) (USA)
- #90688FC AIRBELT K3 Premium - Onyx (Black) (Canada)
- #90693AM AIRBELT K3 Premium - White (USA)

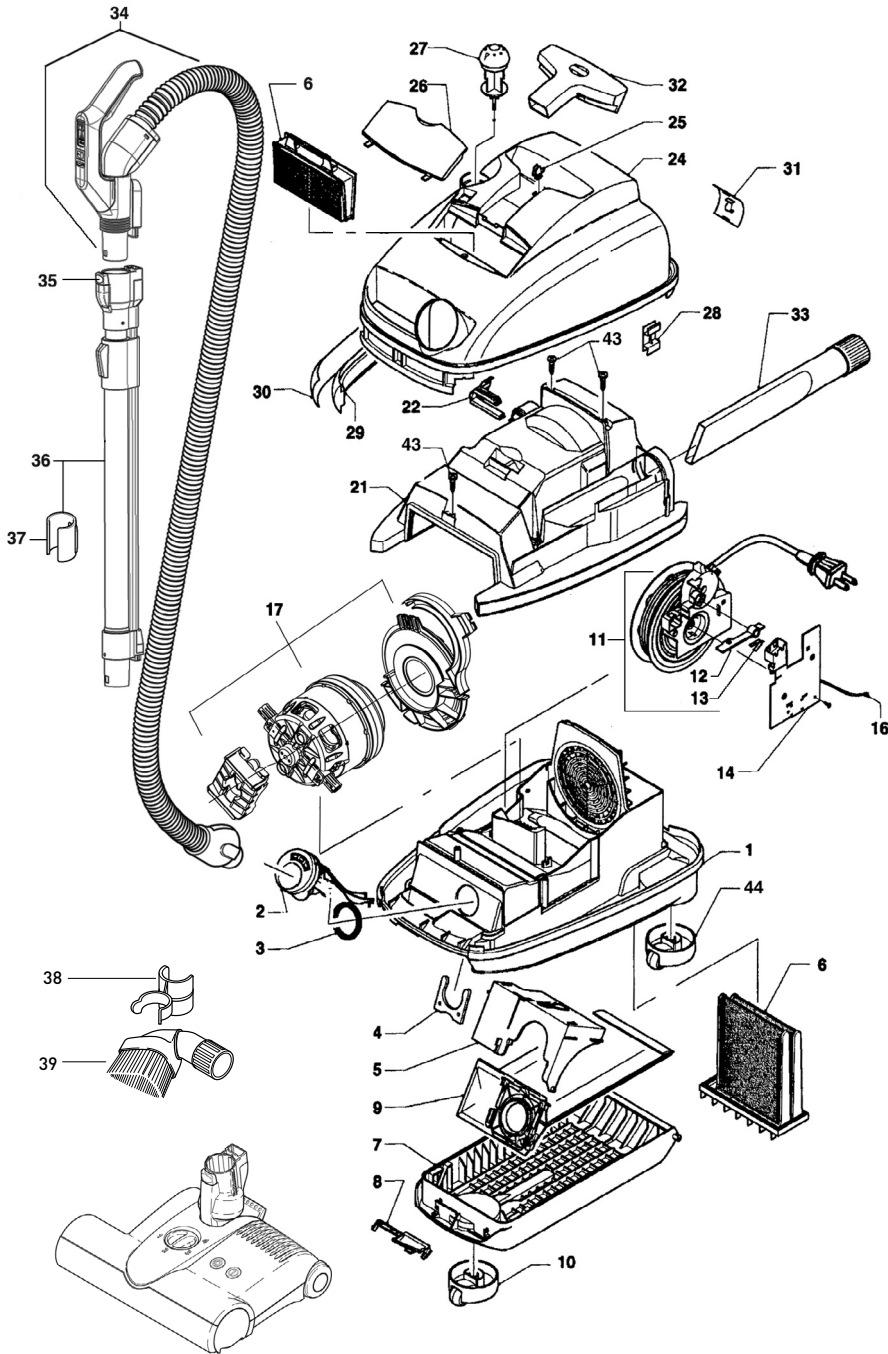

ET-1 Power Head included with K3 Premium
Refer to ET-1 Manual for parts identification

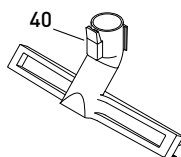

Parquet Brush included with AM Models #6391DA

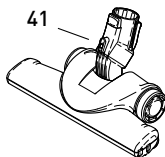

Premium Parquet Brush included with FC Models #7200GS

Canister with Handle/Hose

#90687AM, #90687FC K3 Premium Red Machine

Pos.	Part #	Description
1	6754GS	Bottom casing w/castors (44)
2	6677GS	Suction neck
3	6014	Seal
4	6042WS	Spring lock
5	6681HG	Bag holder, complete
6	6696AM	Pre-motor microfilter & exhaust filter set
7	6756GS	Bag cover w/castor (10)
8	6607GS	Cover release
9	6629AM	AeraPure™ filter bag
10	6752GS	Castor for bag cover
11	665603E	Cord re-winder w/lever & leaf spring [12&13]
12	6621	Switch lever w/leaf spring [13]
13	1739	Leaf spring
14	6645ER	Electronic controller K3 w/switch
16	6638	Internal cable, white
17	6631ER	Vac motor 1250W includes motor mount, adaptor, internal cable w/thermal cut-off (pos. 15)
21	6679GS	Motor cover
22	6622GS	Plug surround
24	6680DR1	Top Casing, red (25)
25	6625ER	Release clip w/screw
26	6403DREER	Exhaust filter cover, red
27	60666WE	Power knob, white
28	6086HG	Casing clip
29	6623UL	Foam bumper - K Series
30	6047AM01	AIRBELT textile, gray black, solid (incl. pos. 31)
31	6048GS	AIRBELT clip
32	6627GS	Upholstery nozzle
33	1092GS	Crevice nozzle
34	8545AM	7' hose & handle, complete assembly only
35	6420GS	Handle release button w/leaf spring & cap
36	60237UC	Telescoping tube w/brush adaptor 60238AD pos. 37
37	60238AD	Brush adaptor
38	6694GS	Clip for dusting brush
39	1387GS	Dusting brush
40	6391DA	AM models: Parquet Brush
41	7200GS	FC models: Premium Parquet Brush
43	0105	Screw 3.9 x 19
44	6751GS	Castor for bottom casing

#90688AM, #90688FC

K3 Premium Onyx (black) Machine Exceptions

24	6680SW1	Top Casing, black (25)
26	6403SWER	Exhaust filter cover, black
30	6047AM07	AIRBELT textile, silver/black, ovals (incl. pos. 31)

#90693AM

K3 Premium White Machine Exceptions

24	6680WE1	Top Casing, white (25)
26	6403WEER	Exhaust filter cover, white