

DUO BRUSH MACHINE

#9801AM DUO Brush Machine - Light Gray

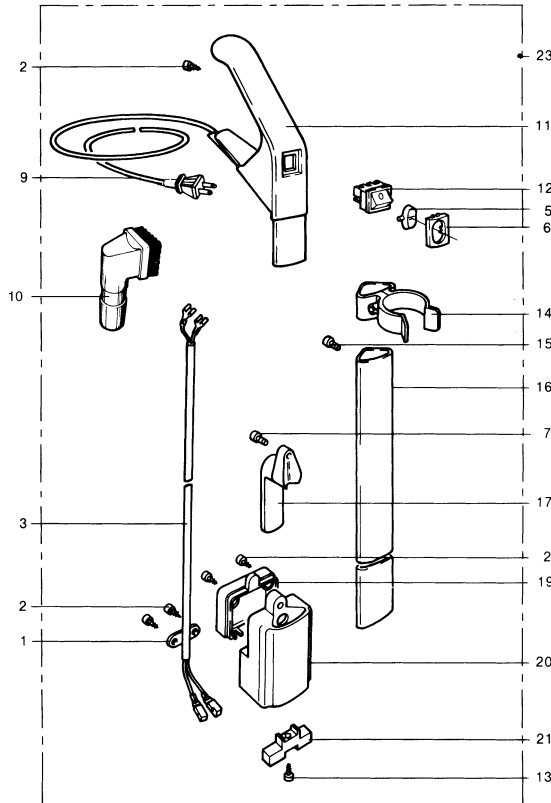

Handle Assembly

9401AM Duo Machine

1	1030 UL	Cable clamp
2	0106	Screw 3.9 x 13 A2
3	3125	Handle cable
5	3137GS	Switch cap
6	3136HG	Switch cap holder
7	0127	Screw taptite M4 x 10
9	5433DG	Cable - dark gray
10	3055HG	Spot cleaning brush
11	3142HG	Handle grip
12	005113	Rocker switch (incl. pos. 5-6)
13	0105	Screw 3.9 x 19
14	5352HG	Clamp
15	0129	Screw taptite M4 x 12
16	3115	Handle tube available only as part of position 23
17	3118HG	Cable hook
19	3027HG	Handle connector cover
20	3113HG	Handle connector
21	1020UL	Contact cover
22	0103	Screw 3.9 x 16
23	3122/H	Handle cpl. (incl. pos. 1-21)

Power Head

22	0103	Screw 3.9 x 16
25	3033HG	Storage tray
26	2007MG	Bumper
27	3005ER	Brush roller
	3005W	Soft brush roller
28	3002SW	Base plate
29	0112	Screw M4 x 10 A2
30	3010HG	Bearing block RH
31	3001HG	Brush housing
32	3032	Handle stop spring block
33	0502	Terminal block
34	3049ER	Motor 120 V
	05084S	Carbon brush set
35	0141	Locking washer
37	3038	Drive belt
38	0176TL	Screw AM4 x 30 A2 DIN 7985
39	3004SE	Cover
41	0149	Spacer washer
44	2438HG	Plunger button, complete
45	2423	Spring
47	2022HG	Swivel neck cover
48	3123HG	Swivel neck
50	3051	Swivel neck support
51	3014	Motor pulley
52	3030	Clamp
53	3013	Pulley
54	3042	Drive belt
55	3022	Gear wheel LH thread
56	3036	Spacer
57	3037	Shaft LH thread
58	0222	Ball bearing
59	3015	Pulley LH thread
60	3039	Bridge
61	3035	Shaft RH thread
62	3021	Gear wheel
63	3018	Pulley
64	3071	Clip
65	3040	End plate
66	3009	Pulley
67	3028	Spring
68	3007	Brush drive cog
69	3074HG	Bearing block
70	3052HG	Bearing block assembly LH
71	3017	Pulley
72	3056	Pulley 12R/Ms

