



MADE IN GERMANY

SEBO FELIX PREMIUM

OWNER'S MANUAL

For Household Use Only



TABLE OF CONTENTS

Technical Details	2
How To Contact SEBO	2
Important Safety Instructions	3
SEBO FELIX Product Features	4
ET-1 Power Head Features.....	4
Standard Features of all SEBO Vacuums	5
S-Class Filtration	5
Optional Attachments, Accessories, Bags and Filters	6
Identification of Parts	7
Standard Attachments	7
Power Head and Floor Tool	7
Assembly	7
Operating Instructions	8
Starting the Machine	8
Operating the Power Head	8
Using the Hose Handle, Hose & Attachments	9
Detachable Suction Unit	9
Full Bag or Clog Indicator.....	9
Brush Obstruction Light & Auto Shut-Off.....	9
The Brush Height Adjustment Feature	9
Indicator Lights.....	9
Power Head Maintenance	10
Removing the Brush Roller	10
Cleaning the Brush Roller	10
Use and Maintenance of Floor Tools and Brushes	10
The Premium Parquet Brush	10
The Premium Kombi Nozzle	10
Vacuum Maintenance	11
Changing the Filter Bag	11
Changing the Pre-motor Filter.....	11
Changing the Exhaust Filter.....	11
Clog Removal	12
Clogs in the Hose	12
Clogs in the Swivel Neck.....	12
Clog Removal in the Power Head	12
Clogs in the Airflow Pathway	12
Clogs in the Swivel Neck	12
Trouble-shooting Guide	13
Additional Trouble-shooting Guide for Power Head	14
FELIX Premium Bag Housing with Handle Schematic and Part Numbers	15
FELIX Premium Power Head (ET-1) Schematic and Part Numbers	16

TECHNICAL DETAILS - VACUUM

Vacuum motor	1000 Watts
Water lift (at motor)	90 inches
Airflow (at motor)	102 CFM
Filter bag capacity	.92 gallon
Sound level	68 dBA
Body weight (depending on the attachment)	9.9 - 15.4 lbs
Cord length	31 feet
Range	34.5 feet

Technical details may be subject to change.

TECHNICAL DETAILS - POWER HEAD

ET-1	
Brush motor	175 Watts, 1.6 Amps
Width	12 inches
Weight	5.4 lbs.
Brush Speed	2700 RPM
Brush roller	Replaceable
Brush drive	Toothed belt with electronic overload protection

Technical details may be subject to change.

HOW TO CONTACT SEBO

To contact SEBO in the United States of America:

SEBO America, LLC
 Telephone: (800) 334-6614 • Fax: (303) 792-9196
 Website: www.sebo.us

To contact SEBO in Canada:

SEBO Canada
 Telephone: (877) 258-5005 • Fax: (800) 270-4807
 Website: www.sebocanada.ca

IMPORTANT SAFETY INSTRUCTIONS



READ ALL INSTRUCTIONS BEFORE USING THIS MACHINE

When using an electrical appliance, basic precautions must always be followed.

To reduce the risk of electric shock, this vacuum cleaner has a polarized plug; one blade is wider than the other. This plug will fit in a polarized outlet only one way. If the plug does not fit fully in the outlet, reverse the plug. If it still does not fit, contact a qualified electrician to install the proper outlet. Do not change the plug in any way. Connect only to the outlet type specified on the serial number plate underneath the machine.

SAVE THESE INSTRUCTIONS.

WARNING: To reduce the risk of fire, electric shock, or injury:

1. Do not leave vacuum while plugged in. Unplug from outlet when not in use and before servicing.
2. Do not use outdoors or on wet surfaces.
3. Do not use near small children or pets. Do not allow to be used as a toy. Use of this product by children should always be supervised by an adult.
4. Use only as described in this manual. Use only manufacturer-recommended attachments.
5. Do not use with a damaged cord or plug. If vacuum is not working as it should, has been dropped, damaged, left outdoors, or dropped into water, take it to a SEBO service center.
6. Do not pull or carry by cord, use cord as a handle, close a door on cord, or pull cord around sharp edges or corners. Do not run vacuum over cord. Keep cord away from heated surfaces.
7. Do not unplug by pulling on cord. To unplug, grasp the plug – not the cord.
8. Do not plug in if power switch is in the “ON” position.
9. Do not use outlets above counters to plug in vacuum – damage to items in the surrounding area could occur.
10. Always carry the vacuum over steps and sills.
11. Do not handle plug or vacuum handle with wet hands.
12. Do not put any object into vacuum openings. Do not use machine with any openings blocked. Keep openings free of lint, hair, and anything that may reduce air flow.
13. Do not re-use filter bags or wash the filters.
14. Do not remove any screws from vacuum.
15. Do not vacuum up anything that is burning or smoking, such as cigarettes, matches, or hot ashes.
16. Do not use vacuum without filter bag and/or filters in place.
17. Turn off all machine controls before unplugging.
18. Use extra care when cleaning on stairs.
19. Do not use machine to vacuum up flammable or combustible liquids such as gasoline or use in areas where they may be present.
20. Machines can cause a fire when operated near flammable vapors or materials. Do not operate this vacuum near flammable fluids, dust or vapors.
21. Maintenance and repairs must be done by qualified personnel.
22. Use only original SEBO replacement parts.
23. Do not use vacuum as a step.
24. Do not use the handle assembly (5), which inserts into the top of the bag housing, to carry the machine. The carrying handle is located on the side of the machine.
25. If vacuum is used on plush carpet or carpet with thick padding, do not leave machine standing in one place with machine turned on.
26. While the vacuum is in use, the power cord should be unwound from the cable reel at least two thirds of its length.
27. Keep hair, loose clothing, fingers, and all parts of body away from vacuum openings and moving parts. Do not place fingers or other body parts under vacuum unless it is unplugged. Do not touch the brush roller while the machine is plugged in.
28. Do not place the power head over rug or carpet edges.
29. Store the vacuum in a dry place at room temperature. When the vacuum is not in use, you should rewind the cord onto the cord reel.
30. Any other servicing should be performed by an authorized service representative.
31. Avoid picking up sharp objects.
32. Always unplug vacuum before connecting or disconnecting either hose or power head.
33. Use a SEBO power head only in combination with a SEBO vacuum cleaner.
34. Do not connect power head to a malfunctioning or damaged vacuum.

SEBO FELIX PRODUCT FEATURES

DESIGNED FOR CARPETS AND HARD FLOORS – The stylish FELIX offers all the flexibility of a canister vacuum in an upright configuration! It has a “flex” neck with amazing 180° steering ability, an ultra-modern filtration system, a detachable suction unit that becomes a hand-held vacuum, and an instant-use suction hose.

Detachable Suction Unit Creates a Hand-held Portable Vacuum – By removing the power head or nozzle, the FELIX instantly transforms from an upright floor vacuum into a handheld portable vacuum, ideal for cleaning stairs, upholstery and car interiors. It can be easily carried using its side handle or the optional shoulder strap attachment.



Superb Maneuverability – A unique 180° turning swivel neck offers superb maneuverability around and under furniture.

Flat-to-the-floor, 6-inch Profile – The vacuum’s low profile makes cleaning under furniture and beds easy!

Instant-use Suction Hose – The integrated instant-use suction hose is always ready! Just pull it out to clean corners, crevices or furniture. Two on-board tools and a range of optional attachments can be fitted to the hose, such as a 20-inch wand for cleaning hard-to-reach areas or a 9-foot extension hose, which creates a total length of 15 feet... Perfect for cleaning stairs.

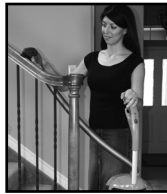

Full Bag or Clog Indicator – When a full bag, a clog in the airflow pathway, or an excessively dirty microfilter is detected, an indicator gauge on the bag housing lid “fills” with orange color and an airflow bypass valve opens, to prevent overheating and motor damage from a lack of adequate airflow.



Three-level Adjustable Handle – This feature provides compact storage, maneuverability when suction unit is detached, and easy adjustment to user height requirements.

Variable Suction Control on Handle with Soft Start – The user can select the suction power needed, from curtains to carpet. And its gradual power-up extends motor life.



Innovative Exhaust Filter...Design and Functionality – Behind the stylish surface hides an ultra-modern S-class exhaust microfilter that not only provides excellent filtration, but it also absorbs motor noise, resulting in extremely quiet operation.

Thirty-one Foot Cord with Rotating Quick-release Hook – It is easy to quickly unwind the cord by rotating the hook!



The FELIX Includes the ET-1 Power Head, Two On-board Tools and Premium Parquet Brush – Along with a commercial quality power head, the FELIX comes standard with a crevice nozzle, upholstery nozzle and a premium parquet brush, which is perfectly designed for cleaning hard floors.

ET-1 Power Head - Designed for All Floor Surfaces.

The power head deep cleans carpets, or its spinning brush roller can be shut off to clean delicate rugs and hard floors with straight suction. It also has easy brush roller removal, and a warning light illuminates when brush height is set too high for optimal cleaning, the bristles are worn, or automatic shut-off occurs due to a brush obstruction.

Power Head with One-sided Edge Cleaning – The FELIX power head is 12 inches wide with a 10½-inch cleaning path.



Multi-surface Cleaning Capabilities – With a power head for carpets and a parquet brush for hard floors, the FELIX provides all the cleaning flexibility of a canister vacuum!

Manual and Automatic Brush Shut Off – The FELIX can clean delicate rugs or hard floors with straight suction because the brush roller can be manually switched off by pressing the green illuminated on/off button on the power head cover. Also, the brush roller automatically shuts off when the suction hose from an attached vacuum is removed from its housing port or when the swivel neck of the power head is in its upright-locked position.



Brush Obstruction Light with Automatic Brush Shut Off – If an obstruction becomes jammed in the brush roller, a red brush-warning light will quickly flash, the brush roller will immediately stop spinning and the vacuum will shut off. The user should turn the power switch off, unplug the machine, and immediately remove the obstruction. If the user restarts the machine without removing the obstruction, the power head will again shut off and the red light will flash. This prevents the belt from breaking and protects the motor and carpet from damage.



Four-level Manual Brush Height Adjustment – The brush can be adjusted up or down for optimal cleaning effectiveness.

Easy Brush Removal and Cleaning – Cleaning hair or other debris from the brush roller or replacing it when its bristles are worn is quick and easy, and no tools are required! This feature ensures consistently effective brush agitation of the carpet pile.

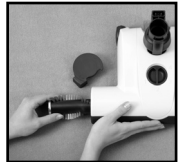

Easy Maintenance – The clog removal door and brush roller are easy to access on the power head.

STANDARD FEATURES OF ALL SEBO VACUUMS

SEBO's FILTRATION SYSTEM:

Bagged vs. Bagless . . . Bags are Better! –

Top-fill, three-layer AeraPure™ Bags are an integral part of SEBO's filtration system because they hold virtually all the dirt captured by the vacuum, which improves the effectiveness and useful life of the microfilters. They also ensure continuously strong suction because dirt enters from the top, deposits at the bottom, accumulates upward, and air exits through the sides, which allows unimpeded airflow as they fill to capacity. And they can be tightly sealed with a hygiene cap when full, so no dust can escape into the air during bag removal and disposal.

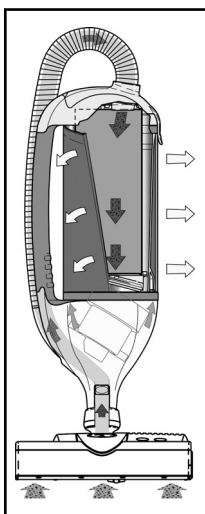

In contrast, without bags to hold nearly all the captured dirt, the microfilters on bagless vacuums quickly clog from excessive dirt build-up and must be replaced often, or a loss of suction and cleaning effectiveness will occur. In addition, dust and other allergens become airborne when emptying bagless dirt containers. Lastly, bagless vacuum microfilters are expensive, usually costing more than a multi-year supply of SEBO filter bags.

S-class, Pre-motor and/or Exhaust Microfilters –

S-class, Pre-motor and Exhaust Microfilters (S = "Schwebstoff" = airborne particles) are made from electrostatically charged, micro-fiber material, which attracts and captures dust particles from the airflow of the vacuum before and after it passes over the motor to cool it. Cooling the motor with super-clean air increases motor life and reduces the possibility of maintenance, even after many years of use. Also, the exhaust air is cleaned to the highest level before being emitted from the machine. The S-class Standard requires filters to absorb greater than 99.9% of particles down to 0.3 microns in diameter. For comparison, 100 microns is the diameter of a human hair. Their advantages are a relatively open texture that allows smoother airflow for better suction performance, a longer life expectancy, and they cost less than HEPA filters.

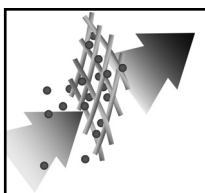

HEPA, Pre-motor and/or Exhaust Microfilters (Optional) –

HEPA Microfilters ("High Efficiency Particulate Air") remove a minimum of 99.97% of all airborne particulate matter down to 0.3 microns in diameter. Because these filters use small, grid-like structures to capture dust particles, dirt build-up clogs the airflow pathway sooner than what is expected from S-class microfilters. However, SEBO's HEPA microfilters are sold along with three-layer AeraPure™ bags, which provide highly effective filtration before the airflow goes through the HEPA microfilter, greatly increasing life expectancy and reducing the potential of diminished air flow.

Designed and Manufactured in Germany – Legendary quality, reliability and performance make SEBO vacuums the first choice of cleaning professionals throughout the world.

World's Best Pet Vacuums – Because of superior power-head and brush-roller technology, SEBO vacuums are the world's best for pet hair removal!

Tightly Sealed Vacuums Ensure Effective Filtration – Dirty air, which flows through a vacuum, can only be filtered completely if it does not escape into the room through seams or seals in the machine. This is why all SEBO vacuums have tight seals throughout.

Many vacuum companies with high-filtration claims are actually quoting specifications made by the manufacturer of the filter material, as measured in the laboratory, not the filtration effectiveness of the vacuum itself while operating. Whether or not dirty air can escape through leaks in the body of the machine is not considered. The filtration effectiveness of SEBO vacuums is tested while they operate.

Reliable, Commercial-grade Components – All SEBO vacuums are constructed with thick, reinforced, ABS plastic, aluminum and metal parts, steel axles and bearings, and high-end, quality motors. Therefore, SEBO users own reliable, long-lasting vacuum cleaners. Competing vacuums are made with thin, flimsy, inexpensive, plastic materials, none of which are reinforced, and typically have useful lifespans of one or two years.

Rubber Wheels and Soft Bumpers Protect Homes – Smooth-gliding, rubber wheels protect hard floors and provide exceptional maneuverability. In addition, the bumpers that surround the power heads and the soft AIRBELT bumpers that surround SEBO's canisters protect furniture, walls, and vacuum housings from incurring scuffs and scratches during use.

Advanced, Brush-Roller Technology – SEBO's brush rollers are uniquely designed to funnel hair and debris into the power head's airflow channel, which improves vacuum cleaning performance on all flooring surfaces.

Changing Bags is Easy and Clean – SEBO filter bags can be changed in just a few seconds, and a hygiene cap keeps dust sealed inside during removal and disposal.

Save Money! SEBO Vacuums Last for Years and Extend Carpet Life!

– If properly maintained, SEBO vacuums save ordinary, residential users hundreds of dollars, by providing excellent performance for ten to fifteen years or more, and their deep-cleaning, power-brush technology extends the life of carpets. Typical vacuums perform poorly, even when new, and usually do not last beyond two years. So six or seven "disposable vacuums" must be purchased during the average life expectancy of just one SEBO machine.

Incredible Warranty Coverage – All SEBO models include a FREE seven-year warranty on the motor and five-years on non-wear parts and labor charges.

OPTIONAL ATTACHMENTS, ACCESSORIES, BAGS & FILTERS

In addition to the standard on-board tools, a variety of optional attachments are available. The 9' 2" foot extension hose (extends suction hoses) and the 22" extension wand are very popular because they create useful tools for cleaning stairs and out-of-reach areas. The Upholstery Nozzle, Extension Wand and Extension Hose are sold separately and are also available as a 3-piece attachment kit. Another popular attachment is the hand-held Turbo Brush with an air driven rotating brush for removing pet hair from upholstery and stairs.

See page 10 for more information on the Premium Parquet Brush and Premium Kombi Nozzle.

SEBO AeraPure™ filter bags can be purchased in boxes of eight. SEBO bags, filters and accessories are reasonably priced and widely available. To create a fresh scent while vacuuming, "SEBO FRESH" is available. To use, deposit a scented stick in the filter bag.

ATTACHMENTS

Included



Premium Parquet Brush
#7200GS



Crevice Nozzle
#1092GS



Dusting Brush with Horsehair Bristles
#1387GS

Optional
Three-piece Kit



22" Extension Wand*
#1084GS



9' 2" Extension Hose*
#1495AM



Upholstery Nozzle*
#1491GS

Exceptions: Crevice Nozzle - Black #1092SW, White #1092JE

*All three items are available individually or as a three-piece attachment kit, #1999AM.

Additional
Options



Hand-held Turbo Brush
#6179ER



Radiator Brush
#1496GS



Flat Upholstery Nozzle
#1090HG



Dusting Brush Large Opening Nylon Bristle
#1094GS



Dusting Brush Nylon Bristles
#1329GS



Premium Kombi Nozzle
#7260GS



Wall & Floor Brush
#1325GS



24" Crevice Nozzle
#1093JV

BAGS, FILTERS, ACCESSORIES and WEAR ITEMS



8 AeraPure™ Bags
#7029AM



Pre-motor Filter
#7012AM



Pre-motor Anti-odor Filter
#7185AM



Exhaust Microfilter black/white, gradation
#7095ER04

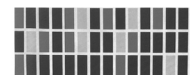

Exhaust Microfilter red/gray, rectangles
#7095ER12



12" Brush Roller
#5010AM



12" Brush Roller (soft bristle)
#5010GE



SEBO FRESH 1 Pkg. of 5
#0496AM



Exhaust Microfilter red/pink, roses
#7095ER37



Exhaust Microfilter indigo/white, blossoms
#7095ER39

IDENTIFICATION OF PARTS

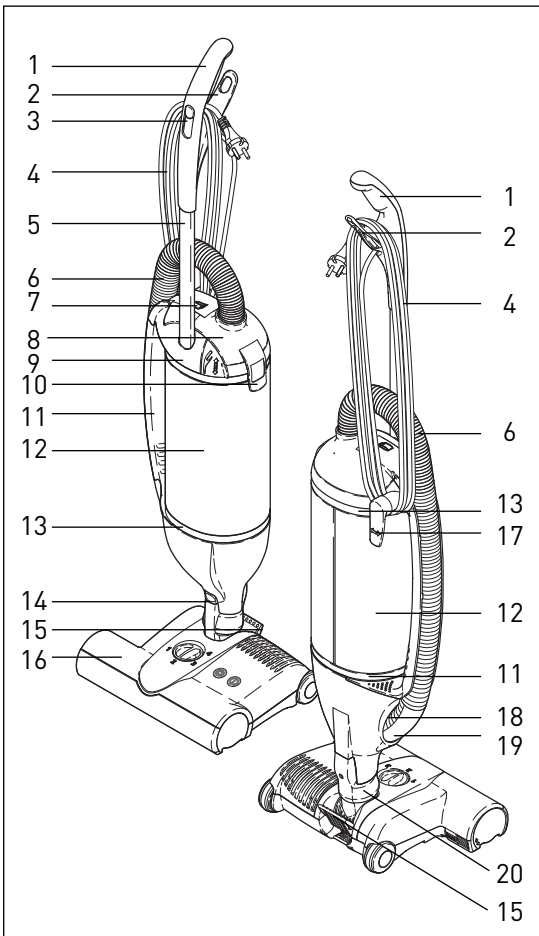

1. Handle grip
2. Upper cable hook
3. On/Off switch, suction control slider
4. Power cable
5. Handle Assembly
6. Hose
7. Bag full indicator
8. Bag housing cover
9. Bag housing
10. Bag housing release latch
11. Carrying handle
12. Exhaust filter
13. Exhaust filter clamps
14. Tool release button
15. Foot pedal
16. Power head
17. Cable hook
18. Suction opening
19. Hose handle
20. Swivel neck

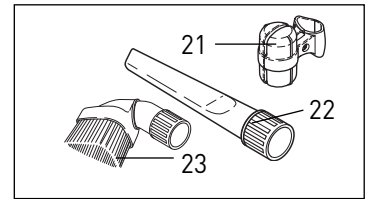

Standard Attachments

21. Attachment Clip
22. Crevice Nozzle
23. Dusting Brush

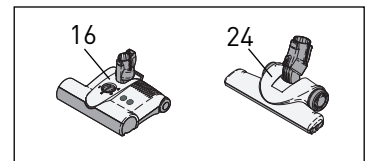

Power Head

16. ET-1: 12-inch Power Head, standard on FELIX.

Floor Tool

24. Premium Parquet Brush, standard on FELIX.

ASSEMBLY

Place the power head (16) on the floor with the swivel neck (20) upright. Hold the vacuum vertically and Insert the suction opening of the vacuum into the swivel neck of the head or tool. Push firmly and evenly downward until the tool release button (14) snaps into the locked position - see figure 1.

Insert the black end of the hose (6) into the connection on the filter cover (8) - see figure 2a. Insert the hose handle (19) into the suction opening (18) on the side of the vacuum - see figure 2b. **Note: Hose must be fully inserted into opening to activate the brush roller.** Press the hose into place on the side of the machine.

Install the attachment clip (21) to the handle assembly (5) using the included screw. Insert the crevice nozzle and dusting brush into the clip - see figure 3.

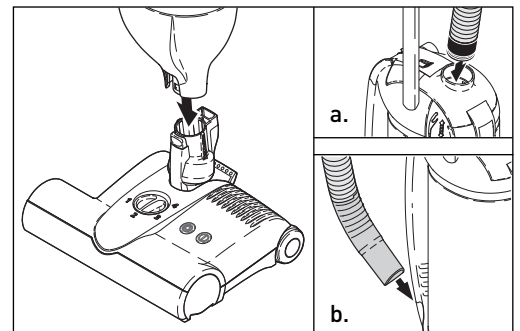

Figure 1

Figure 2

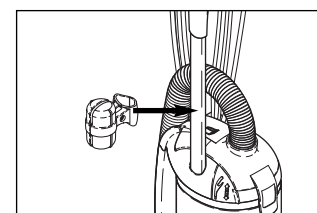

Figure 3

OPERATING INSTRUCTIONS

Starting The Machine - Figures 3, 4 & 5

Before turning on your vacuum cleaner, make sure that the vacuum is in its upright locked position and that you have a firm hold on the handle grip to keep the machine from moving forward.

1. With the power switch (3) in the OFF position, turn the cable hook (17) to the left or right to release the cable (4). Lift the cable off the upper cable hook - see figure 3.
2. Adjust the telescopic handle tube (5) to the correct height by pulling out the handle release lever (32) and gently pulling the tube out to lengthen, or pushing it in to shorten. The tube will click into place when it reaches one of the three lengths available. Release the tab. If the tab does not fit snugly in place, the tube is set at an incorrect setting. Pull or push the tube until it locks into one of the three settings - see figure 4.
3. Plug the polarized power cord into a 120 volt wall outlet located near the floor.
4. Slide the On/OFF switch (3) downward toward the MAX position - see figure 5.

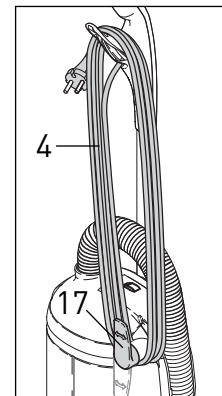

Figure 3

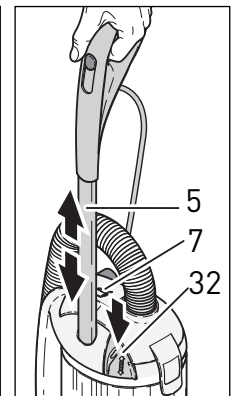

Figure 4

Operating the Power Head - Figures 5, 6, 7, 8 & 11

A. When the power head is switched on with the swivel neck (figure 6) in the upright locked position, the brush roller will not spin and no lights will show. To release the power head from the upright locked position, press down on the foot pedal (15, figure 7) and lower the swivel neck into the normal operating position. If the brush roller does not start, push the on/off button (35, figure 11). The brush roller will then start spinning and the on/off light on the power head will illuminate in green. If the on/off button is OFF, the light will illuminate yellow. The handle can be lowered to a horizontal position useful for vacuuming under beds.

B. To clean delicate or hard floor surfaces with straight suction only, the power head is equipped with an on/off switch (35, figure 11). When this switch is used to turn off the brush roller, the green light will change to yellow, indicating to the user that the brush roller is not turning. Pushing the button again will turn on the brush roller and the light will turn green.

NOTE: The brush roller is off and stopped only when the machine is in an upright position and the handle is completely locked in place, or when the hose handle is removed from the side of the vacuum. If you have the machine at an angle, the brush roller will spin. Leaving the machine in a stationary position for an extended period of time while the brush roller is spinning may cause damage to your floor or carpet. You may also switch off the brush roller by pressing the on/off switch (35, figure 11) on the top of the power head.

C. You may adjust the suction control with the suction control slider (3, figure 5) as you vacuum different surfaces or when using the accessory tools. For optimal cleaning and brushing, operate the machine at the maximum suction power setting and push the power head slowly over the carpet.

Always turn the power switch off when changing heads or unplugging the vacuum. Slide the power control slider on to its OFF position, then unplug the vacuum when changing heads or storing the vacuum. Make sure the handle is in its upright locked position before letting go of the handle. **NOTE: When switching off the power switch, always make sure the switch "clicks" into the OFF position before unplugging the power cord.**

When you have finished using the vacuum, turn it off by sliding the on/off switch to the OFF position. Then, unplug the cord and wind it onto the upper cable hook and upper hook. The rubber tip on the end of the handle allows the vacuum to be propped against a wall without damage.

The use of a power head is recommended for the optimal cleaning of carpets. The rotating of the swivel neck (20, figure 8) allows the power head to steer left and right.

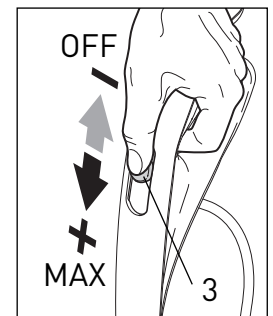

Figure 5

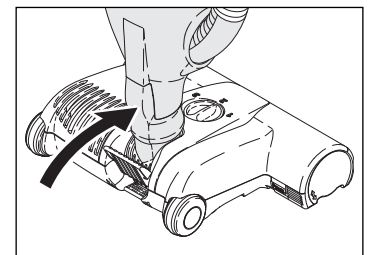

Figure 6

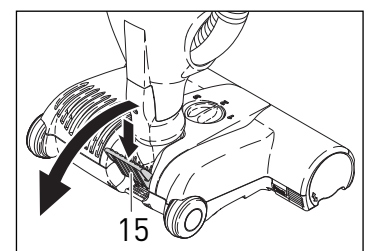

Figure 7

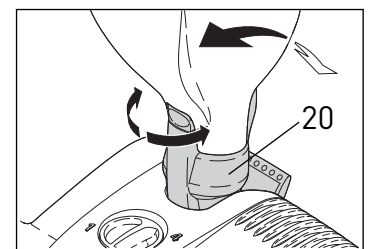

Figure 8

WARNING! *The quality, condition, coating, texture, age and manufacturing technique of all floor surfaces vary. Therefore, vacuums with rotating brushes, including your SEBO, may damage some floor coverings or surfaces. Some types of high-gloss hardwood floors, cushion vinyl, berber carpets, long shag, and delicate or hand-woven carpets are particularly vulnerable to damage by rotating brushes. When possible, consult the materials supplied by your flooring manufacturer for information on proper upkeep and cleaning.*

To ensure that your new SEBO vacuum cleaner is compatible with your floor, please test the vacuum cleaner on each type of flooring surface in a small inconspicuous area to determine if any damage occurs.

If damage occurs, stop using the vacuum cleaner immediately!

Using the Hose Handle, Hose & Attachments - Figure 9

The hose handle (19) is useful for vacuuming corners and hard-to-reach areas. You may use the hose handle with or without an attachment. Pull the hose handle (19) from the suction opening (18) in the side of the vacuum. Keep a firm hold on the handle grip while using the hose handle as it could tip if the hose is pulled too far. The standard attachments [the crevice nozzle (22) and dusting brush (23)] and optional attachments (the hand-held Turbo Brush, upholstery nozzle, extension wand and extension hose) may be inserted onto the hose handle. It is not necessary to turn off the vacuum while switching the *attachments* (see above). **NOTE: When using the hose and attachments, keep the vacuum in its upright, locked position.**

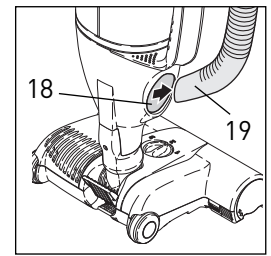

Figure 9

To change a *floor tool* or *power head*, switch off the power and unplug the vacuum. Press the tool release button (14) and pull the vacuum out of the swivel neck (20). Insert the vacuum into the new tool and push down gently until it snaps into place. Plug the vacuum in and switch the power on. You may adjust the suction control with the suction control slider (3, figure 5) as you vacuum while using the power head or when using the accessory or floor tools.

When changing *power heads* and *floor tools*, always switch the vacuum off with the main power switch (3), and then unplug the power cord. **NOTE: When switching off the power switch, always make sure the switch “clicks” into the OFF position before unplugging the power cord.**

Detachable Suction Unit - Figure 10

When detached from the power head, the FELIX transforms itself into a lightweight, powerful suction unit, which can be carried around using its comfortable carrying handle (figure 10). Ideal for cleaning stairs, car interiors or upholstery. To remove a floor tool or power head, switch off the power and unplug the vacuum. Press the tool release button (14) and pull the vacuum out of the swivel neck (20).

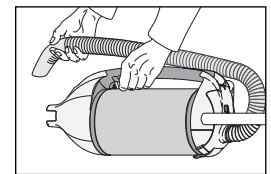

Figure 10

Full Bag or Clog Indicator – Figure 4

When a full bag, a clog in the airflow pathway, or an excessively dirty microfilter is detected, an indicator gauge on the bag housing lid (7, figure 4) “fills” with orange color. The user should turn the switch off, unplug the machine and immediately insert a new bag or remove the clog (to remove a clog, refer to the Clog Removal section on page 12). If the airflow is still restricted, the “BAG FULL OR CLOG” indicator will again display orange to indicate a clog. If the clog is not removed, a bypass valve will open to allow more air into the motor compartment to keep the motor cool.

Brush Obstruction Light & Auto Shut Off – Figure 11

If an obstruction becomes jammed in the brush roller, a red brush-warning light will quickly flash, the brush roller will immediately stop spinning and the power head will shut off. The user should turn the power switch off, unplug the machine, and immediately remove the obstruction. If the user restarts the machine without removing the obstruction, the power head will again shut off and the red light will flash. This prevents the belt from breaking and protects the motor and carpet from damage.

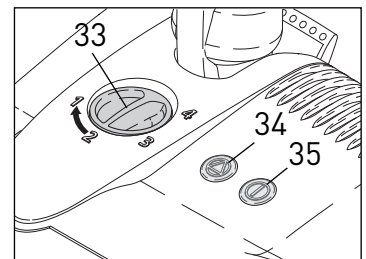

Figure 11

The Brush Height Adjustment Feature - Figure 11

To adjust the brush height, rotate the dial (33) for high carpet (dial setting 4) and progressively lower (bare floor is dial setting 1). The brush obstruction light located on top of the power head (34) will illuminate in red if the height setting is too high. Dial down to the next number until the light is no longer illuminated. If the red light does not turn off when on dial setting 1, the brush roller may be worn.

Indicator Lights - Figure 11

By pushing the foot pedal (figure 7) and lowering the handle, you activate the power head and the brush begins spinning. Failure to use the foot pedal will cause lasting damage to the machine. The electronic brush control constantly monitors the status of the brush, communicating the status through the lights on top.

Green On/Off Light: Brush is on and spinning.
(35, figure 11)

Yellow On/Off Light: The brush roller has been switched off and the vacuum is operating with straight suction only.
(35, figure 11)

Red Brush-warning Light: The brush is not fully engaged in the carpet. The height adjustment should be lowered. If the height adjustment is at its lowest setting, the brush is worn and needs to be replaced.
(34, figure 11)

Red Brush-warning Light Flashing: The brush is blocked. Turn off the power head, disconnect it from the power source, and then remove the blockage (see page 12).
(34, figure 11)

POWER HEAD MAINTENANCE



Always unplug vacuum from outlet before dismantling any part of the machine!

To remove the power head, switch off the power and unplug the vacuum. Then, press the tool release button (12) and pull the vacuum out of the swivel neck.

Removing the Brush Roller - Figure 12

To remove the brush roller, press the button marked "PRESS" (36) and turn the brush roller end cap (37) downward. Turn the brush (38) slightly to the right and pull it out. We recommend regular removal of threads and hair which have wound around the brush roller.

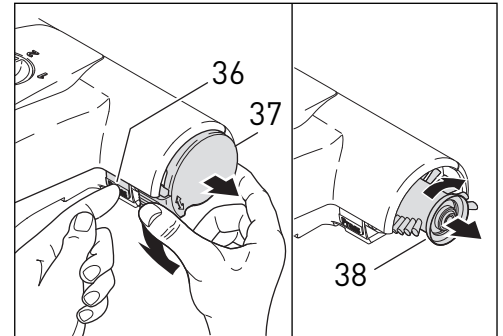
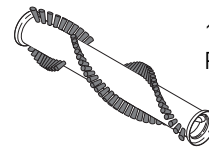

Figure 12

Cleaning the Brush Roller

Unplug the vacuum before attempting to clean the brush.

The brush should be cleaned regularly. Fibers and hair can be pulled out of the brush while manually rotating the roller, or the roller can be removed from the power head to clean it.



12" Brush roller
Part # 5010AM

USE AND MAINTENANCE OF FLOOR TOOLS AND BRUSHES



Always unplug vacuum from outlet before dismantling any part of machine!

To remove a brush or floor tool, switch off the power and unplug the vacuum. Then, press the tool release button (14) and pull the vacuum out of the neck.

Premium Parquet Brush - Figure 13

The Premium Parquet Brush is specially designed for use on hard surfaces. The brush should be cleaned regularly. Remove the parquet brush from the vacuum to clean. Fibers and hair can be pulled out of the bristles manually, or vacuum the bristles using the flexible hose.



Figure 13

Premium Kombi Nozzle (optional) - Figure 14

The optional Premium Kombi Nozzle is adjustable for carpet or hard floors. To set for carpet, slide the up arrow button (39) to the right until it clicks into place. The hard floor dusting brush will raise up allowing the head to move over the carpet. To set for hard floors, slide the down arrow button (40) to the left until it clicks into place. The brush will lower to gently sweep your floors. **The slider in Figure 14 is set in the position for carpet.** The brush should be cleaned regularly. Remove the Kombi nozzle from the vacuum to clean. Fibers and hair can be pulled out of the bristles manually, or vacuum the bristles using the flexible hose.



Figure 14

VACUUM MAINTENANCE



Always unplug vacuum from outlet before dismantling any part of machine!

When the “bag full” indicator (7) displays, airflow is reduced due to a full filter bag, dirty filters, or a clog. If the filter bag is empty and the filters are clean, you may have a clog. Refer to page 12.

Changing the Filter Bag - Figures 17 & 18

To change the filter bag, set the canister upright, open the bag housing cover (8) by pulling the cover release flap (10) upward (figure 17). Seal the filter bag with the sealing cap (42). Grasp the sealing plate (44) of the filter bag with your thumb and forefinger as shown in figure 18 and lift the filter bag (43) out. Lower a new bag into the holder, making sure that the 4 small tabs (indicated by arrows on the sealing plate) fit into the appropriate grooves. The front tab (45) of the sealing plate will fit loosely over the wire latch lock. Push the bag housing cover (8) down firmly and snap the cover release flap (10) into place. For your convenience, there is a diagram on every filter bag showing the correct placement of the bag. Do not re-use the filter bags. **NOTE: The nature of the contents of the filter bag will affect the point at which it needs changing. Fine dust may require an earlier change even though the bag is not full. Fluff or hair allows air to pass through easily, so the filter bag may overflow before the orange “bag full” indicator displays.**



AeraPure™
Filter Bag
Part # 7029AM

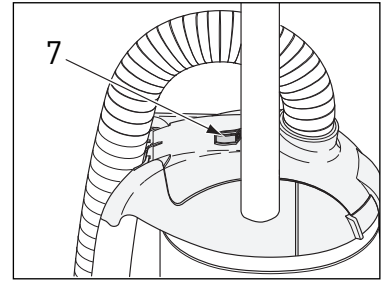

Figure 16

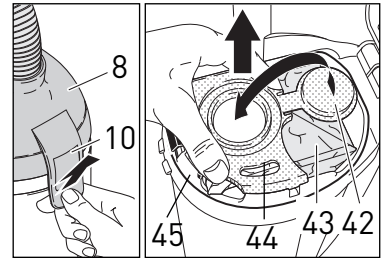

Figure 17

Figure 18

Changing the Pre-motor Filter - Figure 19

After 10 to 20 bags have been used, change the pre-motor filter (46). To remove the filter, set the vacuum upright, pull the cover release flap (10) outward and open the bag housing cover (8). Remove the filter bag (see above). Grasp the handle (47) on the filter and pull it out. To replace, use the handle (47) to hold on to and slide the new filter down into the bottom of the bag housing. When correctly seated, it will snap into place. Insert the filter bag, close the bag housing cover.



Pre-motor Filter
Part # 7012AM

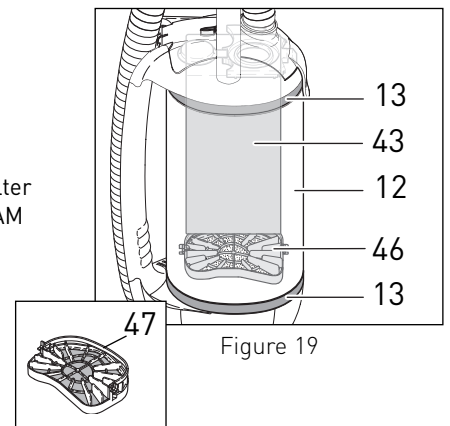

Figure 19

Changing the Exhaust Filter - Figures 19 & 20

The exhaust filter (12) needs to be changed when it becomes extremely dirty or clogged with carbon dust, or after approximately 15 to 20 filter bags have been used. To remove the exhaust filter, set the vacuum upright, and remove the filter retaining rings (13). To release the filter retaining ring, use your thumb to push the retaining ring clip the direction of the arrow, then pull the end of the clip up. Pull the plastic reinforced fabric strips out of the housing slot (48), and remove the filter. To replace the filter, insert the plastic strip on one end of the filter into the housing slot (48) and hold in place with one hand while wrapping the filter around the machine, pulling it taut. While holding the filter together, insert the top of the plastic strip into the slot. While holding the top of the strip in place, push the rest of the strip firmly into the slot. Replace the retaining rings. **NOTE: When reassembling, please ensure that the exhaust filter is fitted correctly in the housing slots and the filter retaining rings are installed correctly. Otherwise, the filter will be ineffective.**



Exhaust Filter
Part #:
7095ER04 - Onyx
7095ER12 - Rosso
7095ER37 - Rose
7095ER39 - Indigo

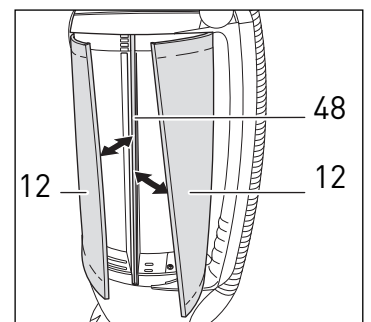

Figure 20

NOTE: Never operate the vacuum with incorrectly attached filters or without filters, filter bag, or bag housing cover (8). Do not re-use filter bags. Do not wash and re-use filters.

CLOG REMOVAL

 **Always unplug vacuum from outlet before removing any clogs!**

Clogs in the Hose - Figures 21, 22, 23 & 24

Check for suction at the end of the hose (6) by pulling the hose handle (19) out of the suction opening (18). If you can only feel a small amount of suction, the clog is in the hose. To clear a blockage in the hose, hold the hose handle upright with one hand blocking the top and switch on the machine. Quickly lift your hand on and off the end of the hose. If that does not clear the clog, you may also clear clogs by reversing the hose. To remove the hose from the machine, lift the bag housing cover. Loosen the safety ring (#49, figure 23) located inside the cover by pushing the lever clockwise as shown in figure 23. Remove the hose. Close the bag housing cover and insert the hose handle into the connecting tube (#50, figure 24) of the filter cover. Hold the hose upright with one hand blocking the top and switch on the machine. If necessary, quickly lift your hand on and off the end of the hose. When the clog is cleared, remove the hose handle from the connecting tube. Loosen the safety ring (49) and insert the other end of the hose back into the connecting tube. Release the safety ring so that it secures the hose. Make sure the hose is connected, then close the bag housing cover.

Note: Do not insert a wire or stick into the hose. Doing so may cause damage to the hose.

Clogs in the Swivel Neck - Figure 25

To check for a clog in the swivel neck (20), remove the head by pressing the release button (14). Pull the vacuum out of the swivel neck. Clean out pathway.

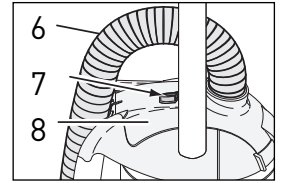

Figure 21

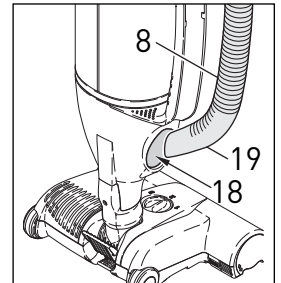

Figure 22

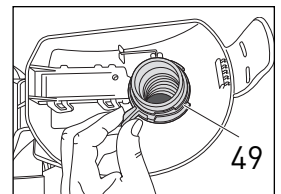

Figure 23

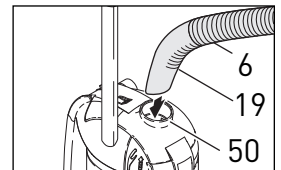

Figure 24

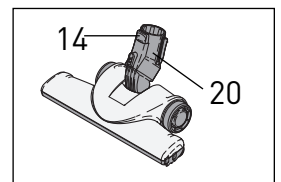

Figure 25

CLOG REMOVAL IN THE POWER HEAD

Clogs in the Airflow Pathway - Figure 26

Many clogs can be removed by accessing the airflow pathway via the orange colored access door (51) located on the underside of the power head.

Clogs in the Swivel Neck - Figures 26 & 27

To check for a clog in the swivel neck (20), remove the head by pressing the release button (14). Push the obstruction down the neck with a stick or long screwdriver and remove it through the orange access door (51).

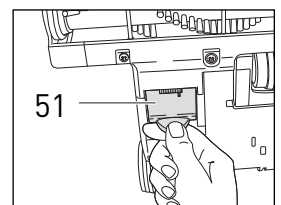

Figure 26

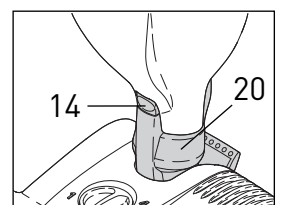

Figure 27

TROUBLE-SHOOTING GUIDE



Always unplug vacuum from outlet before dismantling any part of the machine!

PROBLEM	REASON	SOLUTION
Does not turn on	1. Not plugged into working outlet.	1. Use another outlet.
	2. Cord worn, cut or broken.	2. Replace cord.
	3. The power control slider switch is set to the "OFF" position.	3. Slide slider switch toward the MAX position. See page 8.
Bag full indicator shows	1. Bag full.	1. Replace filter bag. See page 11.
	2. Clog in hose, swivel neck, brush or head	2. See Clog Removal on page 12.
Poor Suction	1. Exhaust filter dirty.	1. Replace exhaust filter. See page 11.
Does not pick up	1. Hose handle is not correctly inserted into suction opening.	1. Reinsert hose handle firmly into suction opening.
	2. Hose is not connected correctly into the connecting tube.	2. Check the safety ring. See page 12.
	3. The suction control dial is rotated to no suction setting.	3. Slide suction control slider to higher suction setting. See page 8.
	4. Bag housing cover not closed.	4. See below.
Bag Housing cover won't fully close	1. Cover release flap not fully closed.	1. Reinsert bag. Lock the cover release flap (10) down firmly.
	2. Bag not inserted properly.	2. Reinsert bag. Lock the cover release flap (10) down firmly.
	3. Cover latch spring bent.	3. Straighten cover latch spring.
Filter bag doesn't fit into position	1. Pre-motor filter not properly inserted.	1. Remove the filter bag and make sure the pre-motor filter is seated correctly See page 11.

NOTE: Please see page 14 for additional power head trouble shooting guide information.

ADDITIONAL TROUBLE-SHOOTING GUIDE FOR POWER HEAD



Always disconnect the power head before dismantling any part of the machine!

PROBLEM	REASON	SOLUTION
Power head does not turn on	1. The switch in the air duct housing is not engaged.	1. Re-insert the hose handle (19) into the suction opening (18).
	2. Not plugged into good outlet.	2. Use another outlet.
	3. The switch on the power head is off.	3. Press the power head brush on/off switch. See page 9.
	4. The internal switch in the swivel neck is off because the machine is in the upright locked position.	4. Release the foot pedal and lower the suction neck to operating level. See page 8.
Red brush-warning light is on	1. Reduced brush action.	1. Brush is not fully in contact with the floor. Lower the height setting.
	2. Brush worn.	2. Replace brush. See page 10.
Yellow on/off light is illuminated	1. The brush roller on/off button on the power head is switched off.	1. Press the power head brush on/off switch. See page 9.
Red brush-warning light is flashing and brush stops spinning	1. Jammed brush roller.	1. Remove brush roller obstruction. See page 10.
	2. Overload shut down from excessively deep but loose carpet pile (e.g., long shag carpet).	2. If carpet pile is too deep and loose, then use a "shag rake" attachment instead of the power head.
Does not pick up	1. Clog in airflow pathway or swivel neck.	1. Remove clog. See page 12.

FELIX PREMIUM SCHEMATIC AND PARTS LIST

- #9807AM FELIX Premium - Onyx (Black/Silver)
- #9809AM FELIX Premium - Rosso (Red)
- #90812AMR FELIX Premium - Rose (Arctic White/Rose) (USA)
- #90812FCR FELIX Premium - Rose (Arctic White/Rose) (Canada)
- #90814AM FELIX Premium - Indigo (Dark Blue/White) (USA)
- #90814FC FELIX Premium - Indigo (Dark Blue/White) (Canada)

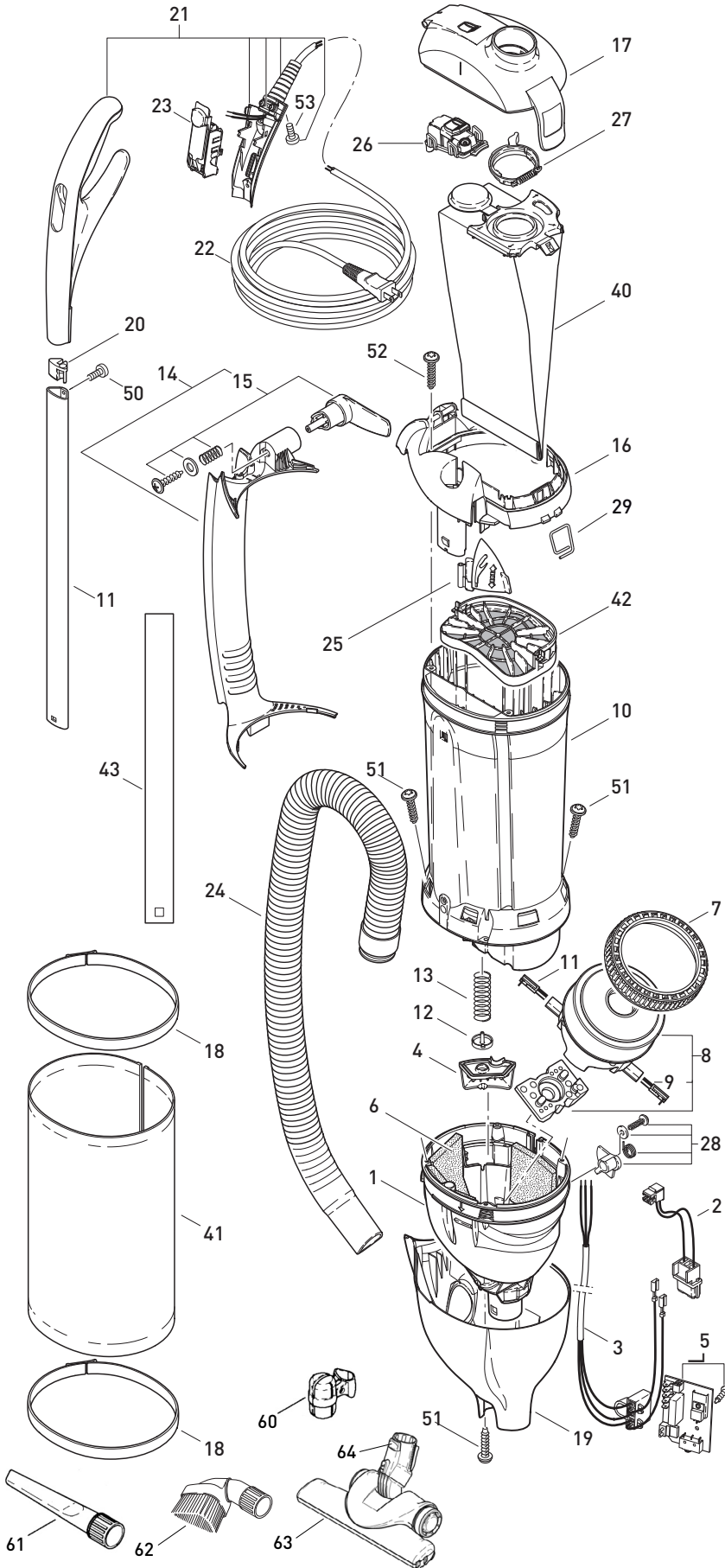

Bag Housing with Handle

#9807AM FELIX Premium Onyx (Black/Silver) Machine

Pos.	Part #	Description
1	7078GS	Air duct
2	7064	Internal wiring ET
3	7071	Internal cable
4	7056GS	Valve cover
5	7111ER	Printed circuit board 120V
6	7098	Sound insulation
7	1047	VAC motor seal
8	7041ER	VAC motor 120V, 1000W
9	05140S	Carbon brush set
10	7143ER	Bag housing
11	7081ER	Handle tube
12	7025	Valve disc
13	8128UL	Valve spring
14	7090SW	Hose duct, black
15	7027SW	Cable hook, black
16	7093SW	Cover, bag housing, black
17	7091SW	Filter cover, black
18	7017SB	Exhaust filter clamp, silver/gray black
19	7173SE	Lower housing, black
20	7076GS	Tube plug
21	7164GSSW	Handle complete, black
22	7127DG	Cable w/plug, 2-wire
23	7038SW	Switch assembly, cpl., back
24	7050SB	Hose cpl., silver
25	7082SW	Handle release button, black
26	7094ER	Filter indicator, cpl.
27	7018OR	Retaining ring, cpl.
28	7032ER	Switch lever, cpl.
29	7024ER	Cover latch spring
40	7029AM	AeraPure™ filter bag
41	7095ER04	Exhaust filter, onyx
42	7012AM	Pre-motor filter
50	0127	Screw M 4x10K
51	01016	Screw STS 4x16-T20
52	01017	Screw STS 4x20-T20
53	01036	Screw 4x14
60	7097SW	Double attachment clip, black
61	1092SW	Crevice nozzle, black
62	1387GS	Dusting brush, gray black
63	7200GS	Premium parquet brush, gray black
	7207ER	Brush strip set (2 pcs. for 7200GS)
64	7212GS	Button cover for 7200GS

#9809AM FELIX Premium Rosso (Red) Machine Exceptions

14	7090DR	Hose duct, dark red
15	7027DR	Cable hook, dark red
16	7093DR	Cover, bag housing, dark red
17	7091DR	Filter cover, dark red
19	7186SE	Lower housing, dark red
21	7164GSDR	Handle complete, dark red
23	7038DR	Switch assembly, cpl., dark red
25	7082DR	Handle release button, dark red
41	7095ER12	Exhaust filter, rosso
60	7097GS	Double attachment clip, gray black
61	1092GS	Crevice nozzle, gray black

#90812AMR FELIX Premium, #90812FCR FELIX Rose (Arctic White/Rose) Machine Exceptions

14	7090WE	Hose duct, arctic white
15	7027WE	Cable hook, arctic white
16	7093WE	Cover, bag housing, arctic white
17	7091WE	Filter cover, arctic white
19	7159WESE	Lower housing, arctic white
21	7164WE	Handle complete, arctic white
23	7038WE	Switch assembly, cpl., arctic white
25	7082WE	Handle release button, arctic white
41	7095ER37	Exhaust filter, rose
60	7097WE	Double attachment clip, arctic white
61	1092JE	Crevice nozzle, light gray

#90814AM FELIX Premium, #90814FC FELIX Premium Indigo (Dark Blue/White) Machine Exceptions

14	7090DB	Hose duct, dark blue
15	7027DB	Cable hook, dark blue
16	7093DB	Cover, bag housing, dark blue
17	7091DB	Filter cover, dark blue
19	70166SE	Lower housing, dark blue
21	7164DB	Handle complete, dark blue
23	7038DB	Switch assembly, cpl., dark blue
25	7082DB	Handle release button, dark blue
41	7095ER39	Exhaust filter, indigo
60	7097GS	Double attachment clip, gray black
61	1092GS	Crevice nozzle, gray black

FELIX PREMIUM SCHEMATIC AND PARTS LIST

- #9807AM FELIX Premium - Onyx (Black/Silver)
- #9809AM FELIX Premium - Rosso (Red)
- #90812AMR FELIX Premium - Rose (Arctic White/Rose) (USA)
- #90812FCR FELIX Premium - Rose (Arctic White/Rose) (Canada)
- #90814AM FELIX Premium - Indigo (Dark Blue/White) (USA)
- #90814FC FELIX Premium - Indigo (Dark Blue/White) (Canada)

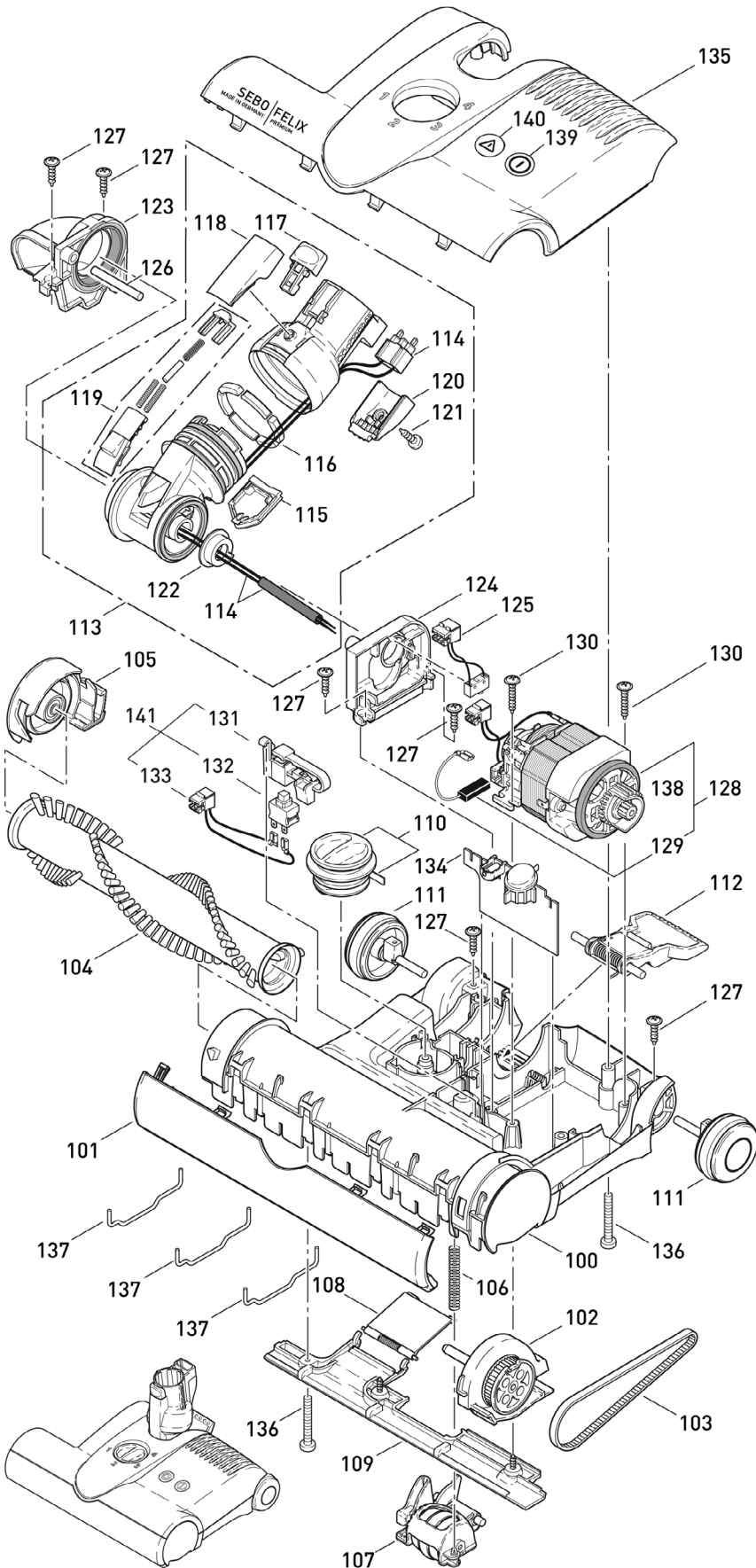

Power Head - 12 inch (ET-1)

#9807AM FELIX Premium Onyx (Black/Silver) Machine

Pos.	Part #	Description
100	2324GS	Chassis ET-1, gray black
101	2302GS	Bumper, cpl., gray black
102	2314GS	Bearing block, left cpl.
103	2923	Belt 333 3M HTDII-6
104	5010AM	Brush roller, cpl.
105	2313GS	Bearing block, right cpl.
106	2929	Spring
107	2316GS	Pile adjustment assembly, cpl., gray black
108	2909VO	Access door w/axle & spring
109	2304GS	Rear bottom plate, cpl., gray black
110	2931SB	Pile adjustment button, silver
111	2306GS	Wheel, cpl., gray black
112	2937OR	Foot pedal
113	2307GS	Swivel neck assembly, cpl., gray black
114	0876ER	Wiring swivel neck
115	2947GS	Cover, gray black
116	2950ER	Segments, TS-neck
117	1737GS	Release button, gray black
118	2952GS	Button cover, gray black
119	2945GS	Swivel neck slide, gray black
120	2951GS	Socket cover, TS-neck
122	2954	Swivel neck bearing
123	2311	Swivel neck support, right
124	2312	Swivel neck support, left
125	0880	Wiring swivel neck switch
126	2928	Axle
128	2973ER	Brush motor 120V, 175W
129	05141S	Carbon brush set
131	2958ER	Lever
132	05114	Switch 2-pole
133	0881	Wiring set foot switch
134	2684ER	Printed circuit board ET1-175W, 120V
135	2360SWSE	Power head cover ET1, black
137	5402	Wire tie
138	2319	Motor pulley
139	2957	On/Off button/lens
140	2956	Brush light lens
141	2959	Switch cpl.
150	01020	Screw F 3.9x21
151	01021	Screw F 3.9x13
152	01027	Screw F 3.9x9.5
153	0176	Screw AM 4x30

#9809AM FELIX Premium Rosso (Red) Machine Exceptions

135	2330DRSE	Power head cover, red
-----	----------	-----------------------

#90812AMR FELIX Premium, #90812FCR FELIX Premium Rose (Arctic White/Rose) Machine Exceptions

100	2324HG	Chassis ET-1, light gray
101	2302HG	Bumper, cpl., light gray
102	2314HG	Bearing block, left cpl., light gray
105	2313HG	Bearing block, right cpl., light gray
107	2316HG	Pile adjustment assembly, cpl., light gray
109	2304HG	Rear bottom plate, cpl., light gray
110	2931HG	Pile adjustment button, light gray
111	2306HG	Wheel, cpl., light gray
113	2307HG	Swivel neck assembly, cpl., light gray
115	2947HG	Cover, TS-neck, light gray
117	1737HG	Release button, light gray
118	2952HG	Button cover, light gray
119	2945HG	Swivel neck slide, light gray
120	2951HG	Socket cover, TS-neck, light gray
135	2331WESE	Power head cover ET1, white

#90814AM FELIX, #90814FC FELIX Premium Indigo (Dark Blue/White) Machine Exceptions

135	2361DBSE	Power head cover ET1, dark blue
-----	----------	---------------------------------